

An Examination of the North Korean Police State



Ken E. Gause

The Committee for Human Rights in North Korea

Coercion, Control, Surveillance, and Punishment

An Examination of the North Korean Police State

Ken E. Gause

Committee for Human Rights in North Korea
1001 Connecticut Avenue, NW
Suite 435
Washington, DC 20036
(202) 499-7973
www.hrnk.org

Copyright © 2012 by the Committee for Human Rights in North Korea

All rights reserved
Printed in the United States of America

ISBN: 0985648015

Library of Congress Control Number: 2012943393

Coercion, Control, Surveillance, and Punishment
An Examination of the North Korean Police State

Ken E. Gause

Committee for Human Rights in North Korea
1001 Connecticut Avenue, NW
Suite 435
Washington, DC 20036

BOARD OF DIRECTORS

(affiliations provided solely for identification)

Roberta Cohen *Co-Chair*

Non-Resident Senior Fellow, *Brookings Institution*

Andrew Natsios *Co-Chair*

Former Administrator, *USAID*

Professor, *Georgetown University*

Suzanne Scholte *Vice-Co-Chair*

President, *Defense Forum Foundation*

Seoul Peace Prize Laureate

Gordon Flake *Vice-Co-Chair*

Executive Director, *Mike and Maureen Mansfield Foundation*

Helen-Louise Hunter *Secretary*

Attorney and Author

John Despres *Treasurer*

Consultant on International Financial & Strategic Affairs

Greg Scarlatoiu

Executive Director, *Committee for Human Rights in North Korea*

Morton Abramowitz

Senior Fellow, *The Century Foundation*

Jerome Cohen

Co-Director, US-Asia Law Institute, *NYU Law School*

Adjunct Senior Fellow, *Council on Foreign Relations*

Lisa Colacurcio

Advisor, *Impact Investments*

Rabbi Abraham Cooper

Associate Dean, *Simon Wiesenthal Center*



Jack David

Senior Fellow, *Hudson Institute*

Paula Dobriansky

Senior Fellow, Belfer Center, John F. Kennedy School of Government,
Harvard University

Nicholas Eberstadt

Henry Wendt Chair in Political Economy, *American Enterprise Institute*

Carl Gershman

President, *National Endowment for Democracy*

Steven Kahng

General Partner, *4C Ventures, Inc.*

David Kim

Coordinator, *The Asia Foundation*

Thai Lee

President, *SHI International Inc.*

Debra Liang-Fenton

U.S. Institute of Peace

Former Executive Director, *Committee for Human Rights in North Korea*

Winston Lord

Former Assistant Secretary for East Asia, *Department of State*

Marcus Noland

Deputy Director and Senior Fellow, *Peterson Institute for International Economics*

Jacqueline Pak

Professor, *Cornell University*

Katrina Lantos Swett

President and CEO, *Lantos Foundation for Human Rights and Justice*

Richard Williamson

Principal, *Salisbury Strategies*

TABLE OF CONTENTS

About the Committee for Human Rights in North Korea	2
About the Author	4
Preface	5
A Note about Sources	8
Acknowledgments	9
Introduction	10
Part I: The Internal Security Agencies	17
State Security Department (SSD).....	17
Ministry of People’s Security (MPS).....	26
Military Security Command (MSC).....	37
Neighborhood Watch Units (<i>Inminban</i>).....	43
Ad Hoc Social Monitoring Organizations.....	50
Part II: What the Internal Security Agencies Do	54
1. Surveillance of North Korea’s Citizens.....	54
2. Investigation and Detention.....	58
3. The Role of Internal Security Agencies in Trials.....	64
4. The Role of the Internal Security Agencies in Prisons.....	77
Part III: History of the Internal Security Apparatus	88
Formative Years (1945 and 1950).....	88
Purging the Enemies of the State (1950s and 1960s).....	100
<i>Kimilsungism</i> and the Monolithic Guidance System (1970–1980).....	113
Kim Jong-il as Heir Apparent (1980–1994).....	121
Intrigue Following Kim Il-sung’s Death (1994–1998).....	129
Kim Jong-il Regime.....	135
Laying the Groundwork for Kim Jong-un’s Succession.....	150
Kim Jong-un Regime.....	159
Rise of the Security Apparatus.....	164
Conclusion	178
Appendix I: Biographies of Key Internal Security Officials	181
Appendix II: An Example of a North Korean Ministry of People’s Security Decree	200
Appendix III: An Example of a North Korean Arrest Warrant	202

ABOUT THE COMMITTEE FOR HUMAN RIGHTS IN NORTH KOREA

In October of 2001, a distinguished group of foreign policy and human rights specialists launched the Committee for Human Rights in North Korea (HRNK) to promote human rights in that country. HRNK seeks to raise awareness and to publish well-documented research that focuses international attention on North Korean human rights conditions, which have been so closed off from the rest of the world.

The Committee's studies have established its reputation and leading role in the growing international network of organizations committed to promoting reform and transition in North Korea. The Committee's reports have addressed many of the fundamental human rights issues in North Korea. Reports published by the Committee have included:

- *Hidden Gulag First Edition: Exposing North Korea's Prison Camps* (by David Hawk, 2003)
- *Hunger and Human Rights: The Politics of Famine in North Korea* (by Stephan Haggard and Marcus Noland, 2005)
- *The North Korean Refugee Crisis: Human Rights and International Response* (by Stephan Haggard and Marcus Noland, 2006)
- *Failure to Protect: A Call for the UN Security Council to Act in North Korea* (published with DLA Piper LLP, 2006)

- *Legal Strategies for Protecting Human Rights in North Korea* (published with Skadden, Arps, Slate, Meagher & Florn LLP, 2007)
- *Failure to Protect: The Ongoing Challenge of North Korea* (published with DLA Piper LLP, 2008)
- *Lives for Sale: Personal Accounts of Women Fleeing North Korea to China* (by Lee Hae-young, 2009)
- *After Kim Jong-il: Can We Hope for Better Human Rights Protection?* (by Kim Kwang-jin, 2009)
- *Taken! North Korea's Criminal Abduction of Citizens of Other Countries* (by Yoshi Yamamoto, 2011)
- *North Korea after Kim Jong-il: Can We Hope for Better Human Rights Protection?* (by Kim Kwang-jin, 2011)
- *Hidden Gulag Second Edition: The Lives and Voices of "Those Who Are Sent to the Mountains"* (by David Hawk, 2012)
- *Marked for Life: Songbun, North Korea's Social Classification System* (by Robert Collins, 2012)
- *North Korea's Camp No. 22* (by DigitalGlobe, 2012)
- *North Korea's Camp No. 25* (by DigitalGlobe, 2013)

ABOUT THE AUTHOR



Ken E. Gause is the director of the International Affairs Group at CNA, a non-profit research organization located in Alexandria, VA. He also oversees the Foreign Leadership Studies Program.

For the past two decades, his area of particular focus has been the leaderships of countries including North Korea, China, Iran, Syria, and Russia. Mr. Gause's work in this area dates back to the early 1980s with his work on the Soviet Union for the U.S. government. He has produced organizational studies on the leadership institutions associated with the Russian and North Korean ballistic missile programs; and an assessment of how North Korea develops its military doctrine. He has published numerous articles on leadership structures for such publications as *Jane's Intelligence Review*, RUSI's *China Military Update*, and the *Korean Journal for Defense Analysis*.

In addition to his CNA work, Mr. Gause has published widely on the North Korean leadership. In 2006, the Army War College's Strategic Studies Institute published his book, *North Korean Civil-Military Trends: Military-First Politics to a Point*. He is also the author of *North Korea Under Kim Chong-il: Power, Politics, and Prospects for Change*, which was published by Praeger in 2011. His recent research interests include:

North Korean succession politics; the North Korean police state; and North Korean civil-military relations.

PREFACE

Coercion, Control, Surveillance, and Punishment lifts the curtain on North Korea's three main security agencies—the State Security Department, the Ministry of Public Security, and the Military Security Command. Established with Soviet assistance in the mid to late 1940s and modeled on the Soviet secret police apparatus, North Korea's internal security agencies rely on constant surveillance, a network of informants in every neighborhood, and the threat of punishment in North Korea's notorious prison camps to ensure the Kim regime's total control.

Following the death of Stalin in 1953, Kim Il-sung refused to follow the de-Stalinization campaigns that took place in the Soviet Union and Eastern Europe, and instead continued to adhere to the Stalinist interpretation of law as an indispensable tool in the arsenal employed to implement state policy. While rejecting both the Chinese Great Proletarian Cultural Revolution as “left opportunism” and the post-Stalinist Soviet inclination towards a more collective style of leadership as “bourgeois revisionism,” Kim Il-sung put in place his own version of national-communism, centered on his cult of personality. To enforce his rule, he employed methods of oppression rooted in four decades of Japanese occupation of Korea, and especially in the 500 years of the Chosun Dynasty, which preceded the 1905 annexation of Korea by Japan. *Yeon-jwa-je*—guilt by association—imprisonment in political prisoner camps of up to three generations of those suspected of wrongdoing, wrong-knowledge, wrong-association, or wrong-class-background, and *songbun*, North Korea's discriminatory social classification system, both originate in the Chosun Dynasty's feudal practices.

Ken Gause’s unprecedented report draws on extensive research to reveal the key role played by North Korea’s security agencies in the establishment and preservation of the Kim regime through two hereditary transmissions of power. From Pang Hak-se—also known as the “North Korean Beria”—to Kim Pyong-ha and U Dong-chuk, the reader learns about the dark eminences of North Korea’s repressive apparatus and their merciless purges of those perceived as “enemies of the revolution,” then “enemies within the revolution,” and finally of those eliminated as scapegoats for the systemic failures of the regime.

As North Korea’s security agencies ruled over an all-pervasive system of coercion, control, surveillance, and punishment, within their own ranks, competition for favors from the ‘Great Leader’ and the ‘Dear Leader’ often resulted in conspiracy, intrigue, and the rise and fall of even the most powerful of officials. Despite strict surveillance, dissent has also existed in North Korea, especially within the ranks of the military. The report addresses two instances when, in the 1980s and 1990s, what could have become organized dissent was brutally eradicated by North Korea’s internal security agencies.

Through overseeing the *inminban* system—the Orwellian neighborhood watch—North Korea’s security agencies ensure that privacy doesn’t exist, and everyone is under strict scrutiny. Not only criticizing authority, but also unauthorized stays, adultery, absenteeism, or watching South Korean videos are punished with prejudice.

The security agencies play a primary role in restricting the flow of information and ensuring strict ideological conformity through harsh surveillance and coercion. North Koreans must participate in self-criticism sessions or face punishment, even time in a political prison camp. State security agents conduct routine checks to ensure that radio sets remain perpetually tuned to the state frequency, and “109

squads” roam border towns at night, arresting smugglers and confiscating South Korean TV shows and dramas that have entered the country via portable media storage devices. Nevertheless, the report also notes that the advent of post-famine small-scale private economic activity, cell phones, DVDs, USBs, smuggled radios and increased access to foreign broadcasting and bribes are beginning to erode some of the information blockade and political controls. Those North Koreans who assume great risks to gain access to information from the outside world and to impart information show courage, whether their actions are an act of dissent or just the result of wanting to learn more about the world. What might ultimately bring change to North Korea is the increased inflow and outflow of information. The security agencies, however, continue to enforce North Korea’s information blackout, by increasing border surveillance and cracking down on marketplaces, unauthorized phone calls, and foreign broadcasting.

Having ensured the survival of the Kim family’s dynastic regime for six decades, North Korea’s complex and ruthless internal security apparatus will no doubt continue to be a key element of Kim Jong-un’s political control. Greater awareness of how it operates is essential to understanding how the Kim regime remains in power.

Greg Scarlatoiu

Executive Director

Committee for Human Rights in North Korea

July 19, 2012

A NOTE ABOUT SOURCES

Very little information on this topic has been translated into English. Some of the more useful books include:

- Hyun Joon-chon, *A Study of the Social Control System in North Korea: Focusing on the Ministry of People's Security* (Seoul: Korean Institute for National Unification, 2004).
- Dr. Suh Jae-jean and Dr. Kim Kap-sik, *A Study of the North Korean Ministry of People's Security* (Seoul: Korea Institute for National Unification, 2008).
- Yun Tae-il, *The Inside Story of the State Security Department* (Seoul: Wolgan Chosun, 2002). Prior to defecting in 1998, Yun Tae-il was a State Security Department officer.
- Atsushi Shimizu, *An Overview of the North Korean Intelligence System: The Reality of the Enormous Apparatus that Supports the Dictatorship* (Tokyo: Kojin-sha, 2004).
- Hyun Sung-il, *A Study on the Structure of the North Korean Worker's Party and its Control System Over the Society* (Seoul: Hankuk University of Foreign Studies, 1999).
- Chae Gyeong-hee, *A Study on the Neighborhood Unit in North Korea* (Seoul: University of North Korean Studies, 2007).

This study also makes extensive use of recent human rights studies by the Korean Bar Association and the Korean Institute for National Unification, both entitled *White Paper on Human Rights in North Korea*. These reports, based on interviews with defectors, delve deeply into the recent revisions of the North Korean Penal Code and Criminal Procedure Act. The author is also indebted to the works of Andrei Lankov, one of the few historians to write on the North Korean security apparatus. This study makes frequent references to his books on North Korean history and politics.

ACKNOWLEDGMENTS

The author would like to acknowledge the support of several research and translation staff who have contributed to this report. Chung Hee-sung took the lead in coordinating research and interview efforts for the author's trip to South Korea in April 2009. In addition, his analysis of North Korean law and his translation and analysis of Korean materials was vital to this project. N. Sato, likewise, provided research and translation of Japanese materials, some of which contain information not found anywhere else in the open source literature.

The author wishes to thank the two HRNK Co-Chairs, Roberta Cohen and Andrew Natsios, for taking the time to review later versions of the manuscript. Thanks also to former HRNK Executive Director Chuck Downs for his substantive comments and detailed copy-editing of successive draft manuscripts, and to current HRNK Executive Director Greg Scarlatoiu for his work to complete the publication.

Special thanks to HRNK interns: Rosa Park, for copy-editing of the manuscript, text arrangement, graphic design, and background research; Mintaro Oba, for copy-editing and background research; Hyungchang Lee, for copy-editing and ensuring compliance with the Revised Romanization of Korean system; Jason Keller, Su Park, Daniel Aum, Yi Yi He and Dongkeun Lee, for conducting background research.

Finally, the author would like to thank the dedicated network of researchers and Pyongyang watchers throughout Asia, who conducted numerous interviews and tirelessly provided material for this study. Given the sensitivity of their work, they will remain anonymous.

INTRODUCTION

Many people expected North Korea to collapse soon after the end of the Cold War, when its Soviet sponsor fell. Similar expectations accompanied Kim Il-sung's death in 1994. The regime's breakdown appeared imminent during the years of famine in the 1990s when hundreds of thousands of people suffered from starvation and fled their home country, but the Kim regime survives. In the aftermath of Kim Jong-il's death in December 2011, there has been some discussion of regime viability in the coming years, but expectations are for near-term stability.

One of the reasons for political continuity despite economic deprivation is the total control the regime maintains over society. North Korea is a police state. Telephones and correspondence are monitored, radios are fixed to receive only government authorized stations, travel and activities are controlled, and people's thoughts are continually molded and monitored. Anyone not conforming to regime directives is considered suspicious and a potential enemy of the state. An elaborate caste system classifies the population into discriminating categories based on the regime's determination of a person's loyalty and assigns every individual a narrowly prescribed role in society. Informant networks exist in every social, economic, and political group.

Overseeing this apparatus of coercion and repression are a number of internal security—or domestic spying—agencies. Each has its own missions and responsibilities, but often the lines of responsibility are blurred. Jurisdictional fights between agencies vying to prove their absolute loyalty to the Supreme Leader (first Kim Jong-il, now Kim Jong-un) have been commonplace, with severe consequences for officers of the security agencies and for the people of North Korea. The three major agencies responsible for internal security include the following:

- The **State Security Department (SSD)** is often referred to as the Ministry of State Security (MSS) and carries out a wide range of counterintelligence and internal security functions normally associated with “secret police.” It is charged with searching out anti-state criminals—those accused of antigovernment and dissident activities, economic crimes, and disloyalty to the political leadership. Political prisons are under its jurisdiction. It has counterintelligence responsibilities at home and abroad, and runs overseas intelligence collection operations. It monitors political attitudes and maintains surveillance of those who have returned from other countries.
- The **Ministry of People’s Security (MPS)** is responsible for internal security, social control, and basic police functions. It is one of the most powerful organizations in North Korea and controls an estimated 210,000 public security personnel. It maintains law and order, investigates common criminal cases, operates the prison system, monitors citizens’ political attitudes, conducts background investigations, census, and civil registrations, controls individual travel, controls the traffic, manages the government’s classified documents, protects government and party officials, and patrols government buildings and some government and party construction activities.
- The **Military Security Command (MSC)** is the investigative unit of the armed forces. Not only does it provide an additional layer of surveillance in the Korean People’s Army (KPA) beyond what is provided by the General Political Bureau, it also contributes to the personal protection of the Supreme Leader. Its primary responsibilities are monitoring

the loyalty of the high command and ferreting out possible coup plots in the armed forces. As its responsibilities grew in the 1990s, the Security Command also took on some limited, non-military investigative missions at the provincial level.

While this security apparatus may be reminiscent of other Communist, totalitarian systems, there are components of the North Korean police state that are unique. At the most basic level, surveillance is the responsibility of each individual of the state. North Korea has instituted an elaborate neighborhood watch program called the *inminban* system. Every North Korean citizen is required to belong to an *inminban*, which monitors its members, provides ideological education, and serves as a conduit for various mobilization campaigns. The head of each neighborhood *inminban*, consisting of 30 to 40 households, reports to the security agencies listed above on a regular basis.

North Korea is a country that defies conventional characterization. Often described as Stalinist or totalitarian, the regime in Pyongyang does not easily fit into convenient definitions applied to the most oppressive Communist regimes of the past. It is true that North Korea has an official ideology (*juche*), a mass party (the Korean Workers' Party or KWP) headed by a single dictator, and a system of control over the levers of power and terror (i.e. the secret police). But it is how these pieces of the totalitarian puzzle fit together that makes North Korea unique and explains how the regime controls society.

As is true in any authoritarian or totalitarian regime, maintaining internal security is a vital task since the leadership cannot count on popular legitimacy to remain in power. North Korea's internal security apparatus is highly effective in this role. It has limited

the communication and social congregation that would be necessary to spawn civilian uprisings. Security activities have also prevented counter-regime groups from forming within the military and other branches of government, although periodic purges suggest that some dissent exists or is perceived by the regime.

One weakness of the security apparatus is that it is fragmented. While this fragmentation prevents the emergence of a monolithic security force that could potentially threaten the regime, it makes coordination difficult. In addition, the various security organs watch each other and engage in competition despite their specific missions and boundaries.

North Korea's security organs have chains of command in the party and government apparatus. These lines of control originated in Kim Jong-il's rise to power and his subsequent consolidation of power in the years after Kim Il-sung's death. During his time as heir apparent in the 1970s and 1980s, as director of the KWP Organization and Guidance Department, Kim Jong-il was able to issue orders and guidance to close aides within the State Security Department (SSD) and the Public Security Department (later the Ministry of Public Security (MPS)). As a consequence, these two police agencies took the lead in guaranteeing his control over the government and remain powerful today.

Kim Jong-un's relationship to the internal security organs remains to be seen. Defector reporting suggests that he has spent a great deal of time since becoming heir apparent in 2009 forging ties to key security leaders and overseeing internal security policy, including a severe crackdown on North Korea's border with China in 2011 and 2012.

In most countries, the Constitution acts as the Supreme Law of the Land, but in North Korea that is not the case. Other Communist countries have placed control

of the state and its legal system under the Communist Party, so there is precedent for Article 11 of North Korea's Constitution, which states that the "Democratic People's Republic of Korea shall conduct all activities under the leadership of the Workers' Party." In North Korea, however, the bylaws of the Workers' Party state that "the Workers' Party takes the revolutionary thought of the great leader, Kim Il-sung, and the *juche* ideology as the one and only leading guideline," making it clear that the Workers' Party's absolute guideline is what Kim Il-sung instructed. *Juche* ideology simply prescribes absolute loyalty to the *suryeong*—the leader—so *juche* ideology itself can only be interpreted by the leader. Thus, whatever the leader says, goes. According to one study of this legal system:

In North Korea, the teachings of Kim Il-sung, the words of Kim Jong-il, and the precepts and principals of the Party have come to function as supra-legal structures... Because of this, actual criminal law has lost much of its meaning. The directives of official successor Kim Jong-un have also taken on supra-legal applications. His directives have been used most prominently in cracking down on and punishing defectors.¹

Article 79 of the North Korean Constitution stipulates that "Citizens are guaranteed inviolability of the person and the home and privacy of correspondence," and "No citizens can be placed under control or be arrested, nor can their homes be searched without a legal warrant." In fact, however, North Korean authorities routinely violate this article and have established a system dedicated to its violation.

¹ Lee Kyu-chang and Chung Gwang-jin, "The North Korean Criminal Trial System: Characteristics and Actual Practices," KINU Research Abstract 11-05, 2011.

Following Kim Il-sung's death in 1994, his son Kim Jong-il assumed power and his dictates over-ruled the Supreme Law. The Korean Bar Association has pointed out that in North Korea, the hierarchy of "law" is: Kim Jong-il's and Kim Il-sung's words, Workers' Party instructions, the Socialist Constitution, other statutory laws, and finally rules and regulations.² The security agencies serve only the leader himself; their severe methods of coercion and control are not in service of law, or of the people of the nation.

Under the Kim regime, there is no representation of the will of the people, either as individuals or as a collective group. Kim Jong-il had the means to operate the government based on clandestine rules and orders based on his personal whim, unchecked. While Kim Jong-un may be more dependent on a collective support network, all initial indications are that he will run the regime in a similar manner. Why this system of clandestine control leads to human rights violations may be readily apparent to those who live in free societies. The will of the nation's people is neither represented in a freely elected legislative body nor in an elected executive authority; furthermore, there is no independent judiciary, so the people have no way to guarantee their rights or insist on governmental responsiveness to their concerns.

In North Korea, the leader's orders and instructions are not only absolute, but also obscure and often inconsistent. Ordinary citizens do not have access to reliable written instructions. Indeed, defining the will of the leader is itself a matter that requires an extensive bureaucracy—requiring guidance from Party officials occupying a series of offices set up to promulgate instructions to sectors of the population for which they are responsible. These officials' words are themselves subject to re-interpretation

² 2008 *White Paper on Human Rights in North Korea* (Korean Bar Association, 2009). It remains to be seen whether Kim Jong-un's words will join those of his father and grandfather as dictates of law.

by lower Party officials. It is impossible for the average citizen to question what he is being told by Party officials or argue that the leader actually meant something else. Often the hapless citizens of North Korea find they have offended the regime only when they have been arrested.

Once they are arrested, they are under complete control of police agencies. The police are responsible for criminal investigations, sentencing, and punishment. All of these are conducted in secret, and there is no right of recourse.

North Korea revised its Penal Code and Criminal Procedure Law in 2004 and 2005 reportedly to clarify legal procedures and guidelines governing interrogations, arrests, sentencing, and detentions. Some have seen this move as an attempt by the regime to respond to international condemnation of human rights. It is unclear, however, whether this move has made any difference in how the legal system actually operates. Secret political trials are still held and unpublished rules continue to sanction the disappearance of individuals deemed a threat to the regime. Evidence of public executions persists, as does a host of other abuses that take place, especially in the political prison camps.

PART I: THE INTERNAL SECURITY AGENCIES

State Security Department (SSD)

The State Security Department (*Gukga An-jeon Bo-wi-bu*, SSD) is one of the most obscure institutions in the North Korean regime. Although its existence was known for years, it was not until 1987, at the time of SSD Director Ri Chin-su's funeral, that the North Korean media officially acknowledged the SSD's existence.³ The SSD is often referred to in the outside media as the Ministry of State Security or the State Political Security Department.⁴ Its military cover designation is allegedly KPA Unit 10215.⁵

The SSD's personnel numbers approximately 50,000.⁶ It is headquartered in Pyongyang,⁷ but has offices at the provincial, city, and local levels. The SSD carries out a wide range of counterintelligence and internal security functions normally associated with "secret police." It is charged with searching out anti-state criminals—those accused of anti-government and dissident activities, economic crimes, and

3 In September 2007, the central media unveiled this shadowy institution in a television broadcast devoted to a SSD news conference warning the public against smuggling and use of contraband media and communication devices. The following year, in December, the central media again mentioned the SSD in a story that accused South Korea of plotting to assassinate Kim Jong-il.

4 Also called SSA in the Seoul Human Rights Commission report and NSA in the *Hidden Gulag*, 2003 and 2012.

5 Kim Jong-un's second public on-site inspection after becoming heir apparent in September 2010 was to KPA Unit 10215.

6 According to one Japanese source, the SSD has approximately 70,000 personnel. See "Real Power of the State Security Department," *Economist*, 01 October 2008.

7 In May 2009, *Yonyap* identified Amisan, Taesong ward, Pyongyang as the headquarters location of the SSD. *Yonhap*, 30 May 2009.

disloyalty to the political leadership. It runs political prisons. It has counterintelligence and intelligence collection responsibilities. It monitors political attitudes and maintains surveillance of people who have returned from foreign areas. Department personnel escort high-ranking officials, guard national borders, and monitor international entry points.⁸ The degree of fear it inspires in the Political Security Bureaus of the KPA—which have representatives at all levels of command—is uncertain, but it occasionally takes actions against members of the elite.



SSD Main Complex in Pyongyang (Google Earth as published on North Korea Economy Watch)

In the past, SSD agents were assigned to military units and placed under the control of the Party Committee of the unit. But since the elevation of the Military Security Command in the 1990s, this no longer seems to be the case.⁹ North Korea's unique

8 According to South Korean reporting, the SSD and the Military Security Command are also responsible for security at sensitive defense facilities, such as the Yongbyon uranium enrichment facility. See "Who is in Charge of North Korea's Nuclear Weapons?" *Chosun Ilbo*, 26 December 2011.

9 It should be noted, however, that the SSD occasionally gets involved in cases involving the military. For example, according to a source in Yangkang Province, a number of wives of army officers

internal security system has layers of competing and conflicting responsibilities. SSD agents sometimes assume the role of political officers and ordinary soldiers and focus their monitoring on company-grade officers. They also indirectly supervise the work of the Security Guidance Bureau (SGB), which itself runs a covert monitoring network within the armed forces. Like the SSD, the SGB reports directly to the National Defense Commission (NDC).¹⁰ Internal spies spy on other internal spies.

Structure

The SSD's chain of command is composed of one director, one first deputy director, and several deputy directors. Since Ri Chin-su's death in the late 1980s, the office of director had been officially unoccupied. For years, the duties of this post were presumed to belong to Kim Jong-il directly. Following the Fourth Party Conference in 2012, KCNA announced that Gen. Kim Won-hong had assumed the post.¹¹ The importance of the SSD under Kim Jong-un¹² was revealed as he accompanied his

from the 10th Corps reservist training base in Bocheon County were intending to smuggle some metals out of the country to buy food. When they were caught, officials at the base turned to the SSD in an effort to deal quietly with the matter. However, friction between the SSD and the Military Security Command (MSC) led to a turf battle that generated a "No. 1 Report" that went directly to Kim Jong-il's office. Kim decided to let the MSC handle the matter. "Officer's Families Just Like the Rest," *The Daily NK*, 2 December 2011.

10 Seiichi Ino, *Kim Jong-Il's Will* (Asahi Shimbun Publications, Inc., 2009).

11 At the Fourth Party Conference in April 2012, Kim was made a full member of the Politburo and a member of the Central Military Committee. At the 5th Session of the 12th SPA, Kim was appointed to the National Defense Commission.

12 "Brief History of Member of Presidium, Members and Alternate Members of the Political Bureau of C.C., KWP Elected to Fill Vacancies," KCNA 11 April 2012. In April 2011, the NIS allegedly informed the South Korean National Assembly's Intelligence Committee that Kim Jong-un had assumed the post as director of the SSD. Kim's association with the SSD is rumored to date back to April 2009 when NIS sources contend that he ordered a sting on the vacation home frequented

father on visits to SSD facilities throughout 2009 and 2010, including one to the SSD headquarters in October (2010).

The KWP Administrative Department, headed by Jang Song-taek, is responsible for party oversight of the SSD. According to several sources, one of Jang's deputies has responsibility for monitoring the SSD's activities. Whether this oversight role remains in force since Kim Jong-il's death and Kim Jong-un's assumption of power is unclear. Before his disappearance in early 2012, the day-to-day affairs of the SSD were presumably managed by U Tong-chuk, the first vice director of the SSD, who was appointed as an alternate member of the Politburo and a member of the Central Military Committee at the Third Party Conference in September 2010.¹³ If U Tong-chuk's first vice director portfolio no longer exists, presumably Kim Won-hong is directly responsible for managing the SSD's day-to-day affairs.

Below Kim Won-hong and U Tong-chuk there are six vice directors for organization, propaganda, personnel,¹⁴ inspection, rear "logistics" services, and security.¹⁵ They

by his older brother, Kim Jong-nam. Several of Jong-nam's associates were arrested by the SSD in an apparent purge of "side branches" within the Kim family. See "Kim Jong-un in charge of Intelligence," *JoongAng Daily Online*, 21 April 2011.

13 U Tong-chuk had been appointed to the National Defense Commission in 2010, but was replaced by Kim Won-hong in 2012.

14 To work for the SSD, background checks include investigation back to an applicant's third cousins, because workers at this agency handle many classified materials.

15 According to one source, Kim Sang-kwon, Yun To-sun, and Hong Pong-sik are vice directors in SSD. See Drk. So Chae-chin and Dr. Kim Kap-sik, *A Study of the North Korean Ministry of People's Security* (Seoul: Korean Institute for National Unification, 2008).). Other sources identified Ryu Kyong as a powerful deputy director, who "has received numerous medals for uncovering alleged U.S. and Japanese spy rings within North Korea." In May 2011, however, South Korean sources contend that Ryu was removed as part of a purge to lay the foundation for the Kim Jong-un succession. According to reports, Ryu was arrested by the General Guard Command, interrogated and executed. Speculation was that he was becoming too powerful, even eclipsing U Tong-chuk within the SSD. "N. Korea Purges Deputy Spy Chief," *Chosun Ilbo Online*, 20 May 2011. This purge is similar to the one

oversee more than 20 bureaus, which in turn operate local SSD offices in each province (*do*), city (*si*), county (*gun*), and village (*ri*), as well as organizations and enterprises. Of these bureaus, the First (General Guidance), Second (Counterespionage), Fourth (Counterintelligence), Seventh (Prisons), Eighth (Border Security), Tenth (Investigation), and Eleventh (Prosecution) are the most involved in ensuring the internal security of the regime.¹⁶ Kim Chang-sop, who was elevated with U Tong-chuk to alternate member status in the KWP Politburo at the Third Party Conference, is the director of the Political Bureau.

- **The General Guidance Bureau** is responsible for the dissemination of Kim Jong-un's guidance and instructions. It also serves a number of housekeeping functions, including gathering and analyzing domestic intelligence from all SSD bureaus and preparing overarching, comprehensive SSD reports for Kim.
- **The Counterespionage Bureau** monitors, investigates, and arrests those involved in spying for foreign countries. It also monitors foreign activity within North Korea's borders and conducts immigration functions, such as issuing passports and visas.
- **The Counterintelligence Bureau** (*Ban-tam-guk*) is responsible for ferreting out anti-regime and anti-Kim elements within the North Korean government. It deploys its personnel within the party, government, and military, as well as at universities, enterprises, and factories.

that occurred in the early 1980s when Kim Pyong-ha was removed as head of the SSD and forced to commit suicide. See "Ryu Kyong Had Actual Grip on North Korean Intelligence and Armed Forces," NKChosun.com, 20 May 2011.

¹⁶ According to some defectors, the SSD's 11th Bureau is responsible for surveillance, while the 13th Bureau is dedicated to prosecutorial affairs.

- **The Prisons Bureau** (also known as the **Farm Bureau**) is responsible for the management and control of political prisoners and political prisoner confinement facilities throughout the country.
- **The Border Security Bureau** monitors foreign activity on the border (foreign nationals who might try to enter North Korea), as well as locating and capturing North Korean escapees close to the border. It works closely with the Ministry of People's Armed Forces' (MPAF) Border Guard Command and also operates in China, where it checks the identification of North Korean citizens to determine whether they are escapees. It has arrest authority for high profile defectors but only identifies ordinary escapees for arrest by other SSD elements.¹⁷
- **The Investigation Bureau** (also known as the **Preliminary Investigation Bureau**) investigates and arrests those suspected of anti-regime activities. This bureau is particularly feared by the public for the arbitrary manner in which it carries out executions. Bureau personnel have reportedly assassinated political prisoners for their own personal or career advancement. In recent years, this bureau has devoted much of its time to investigating incidents involving graffiti and leaflets opposing Kim Il-sung and Kim Jong-il and the destruction and damage of their portraits. The Investigation Bureau allegedly keeps files on the handwriting of every North Korean resident over the age of 17 in order to help it identify disobedient individuals.

¹⁷ According to some sources, in April 2012, Kim Jong-un gave the SSD sole authority over border security. Before this move, the SSD and Ministry of People's Security had shared responsibility—the MPAF had the mission for protecting the border and preventing defections while the SSD carried out arrests and repatriations. Now the SSD allegedly is responsible for both roles. "Border Security Goes Back to the NSA," The Daily NK, 22 April 2012.

- The **Prosecution Bureau** is the primary point of contact with the Procurator General and court system. This bureau oversees cases and determines how to proceed with adjudication. Presumably, it is also involved in SSD decisions on whether an individual should be handled as a political criminal or handed over to the Ministry of People's Security.

Other bureaus directly involved in the SSD's internal security function include the Communications Interception Bureau,¹⁸ which may be North Korea's primary signals intelligence agency, responsible for a system of listening posts throughout the country. It monitors internal, foreign, civilian, and military transmissions. Other SSD bureaus are responsible for external intelligence (Third Bureau), protection of Kim Jong-un and other senior officials, as well as a number of administrative and protection services. According to a former SSD officer who defected in the late 1990s, the SSD changes the designations of its bureaus frequently.¹⁹

18 According to one source, communications interception was the responsibility of the 16th Bureau. Another source notes that the 27th Bureau is responsible for developing technology for jamming and monitoring radio waves. It is this latter bureau that is reportedly responsible for cracking down on illegal cell phone use. "No. 27 Bureau of the State Security Department Leads Crackdown on Cell Phone Use in North Korea," *NK Focus*, 21 February 2008.

19 During the research for this study, the author came across different number designations for the same bureau. In all likelihood, the bureau changed designations over the years.

Organizational Chart of the State Security Department²⁰

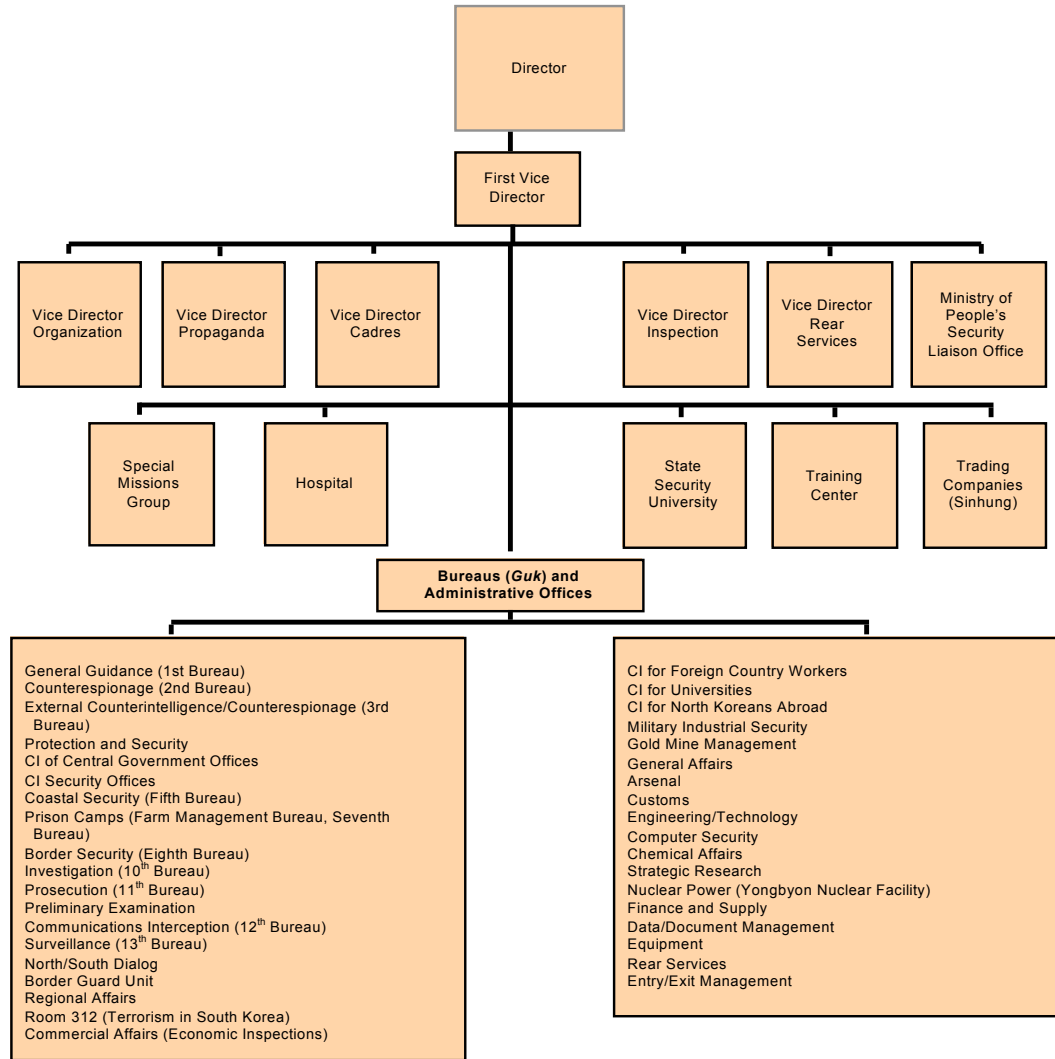

20 This chart is based on interviews and a number of sources, including “State Security Department—Stops Even a Running Train,” Chosun Ilbo, 12 March 2002; Yun Tae-il, *The Inside Story of the State Security Department* (Seoul: Wolgan Chosun, 1998).; Joseph S. Bermudez, Jr., *Shield of the Great Leader* (St. Leonards, Australia: Allen and Unwin, 2001); and Atsushi Shimizu, *An Overview of the North Korean Intelligence System: The Reality of the Enormous Apparatus that Supports the Dictatorship* (Tokyo, Japan: Kojin-sha, 2004).

Each bureau of the SSD is under the direction of a chief and under him are an array of positions including managers (*bujang*), section chiefs (*gwajang*), and guidance members. Of these positions, section chiefs are particularly important, for they control the SSD's agents in the field. Each of North Korea's nine provinces has a SSD office, which more or less replicates the structure of the headquarters in Pyongyang.²¹ The provincial SSD (*An-jeon Bo-wi-bu*) office is headed by a chief and deputy chief, who oversee a number of section chiefs and guidance members.²² Each provincial SSD headquarters has approximately 200 to 300 personnel.²³

In addition to the functional bureaus, the SSD apparatus also includes a hospital, several colleges, a training center, several trading companies,²⁴ and a "Special Mission Group." The Special Mission Group allegedly reported directly to Kim Jong-il, although its current chain of command is unclear. It is charged with conducting surveillance and ideological investigations of high-ranking officials within the KWP, SSD, Cabinet, and Ministry of People's Armed Forces (MPAF). It is supposedly composed of 15 members who were hand selected by Kim Jong-il. Its role and function under Kim Jong-un is not clear.

21 Concurrent with the creation of the SSD in the 1970s, provincial SSD offices were created and assumed the missions of the provincial public security sections (*An-jeon-gwa*) of the provincial public security departments (*An-jeon-guk*). In the 1980s, these offices were re-designated provincial SSD (*An-jeon Bo-wi-bu*).

22 Within the provincial SSD, the chief normally oversees the chemical office, the tourist surveillance department, and the finance department. Counterintelligence and investigative affairs (including the prosecution office) fall under the deputy chief. Discussion with North Korean defector.

23 Although not precise, the number of SSD personnel at the provincial level is based on a ratio of one agent per 1000 people. County (*gun*) level SSDs normally have 70 to 80 personnel. At the district (*gu*) level, the SSD normally has 6 to 10 personnel.

24 A number of offices attached to these trading companies are rumored to be involved in drug smuggling.

Ministry of People's Security (MPS)

The Ministry of People's Security (*In-min Bo-an-bu*)²⁵ functions primarily as the national police in North Korea. According to the Public Security Regulation Law, adopted by the Supreme People's Assembly (SPA) in 1992 and modified in 1999, the ministry is tasked with defending the sovereignty and socialist system of North Korea, as well as protecting the constitutional rights, lives, and assets of the people.²⁶ Within this broad mandate, the Ministry's normal police missions range from maintaining law and order, investigating common criminal cases, and controlling traffic, to overseeing the country's non-political prison system. It also maintains organizations responsible for protecting the country's railroads, key government facilities and officials, as well as resident registration (birth, death, marriage, change of address), the preservation and management of secret documents, and construction and security of sensitive and national infrastructure projects. Like the SSD, the ministry is also responsible for conducting political surveillance, though political suspects are remanded to the SSD for processing. In 2009, the KWP Administration Department expanded the ministry's criminal jurisdiction to include the investigation of offenses committed by the military, SSD, public prosecutors, and cadres of courts in every field except anti-regime crimes.²⁷

25 Some defectors use the short hand *an-jeon-bu* to refer to the regular police. See David Hawk, *Hidden Gulag*, 2nd Edition (Washington, DC: Committee on Human Rights in North Korea, 2012).

26 The "Public Security Regulation" was adopted as the 22nd Decision of the SPA's Standing Committee on December 28, 1992 and modified and supplemented as the 540th Decree of the SPA's Standing Committee on March 24, 1999.

27 This includes the ability to search the houses of suspects from these organizations.

The Ministry maintains a large organization of approximately 210,000 personnel stretching down to the provincial, county, district, city, and village levels.²⁸ Ministry police officers are the most visible face of the North Korean public security apparatus, routinely conducting checks on travellers to ensure they possess appropriate travel documents; maintaining check points to inspect buses, trucks, and trains; and performing normal police patrols.



Ministry of People's Security Headquarters in Pyongyang (Google Earth as published on North Korea Economy Watch)

28 An additional 100,000 civilian staff is attached to the ministry, bringing its total size to 310,000. See Dr. Suh Jae-jean and Dr. Kim Kap-sik, *A Study of the North Korean Ministry of People's Security* (Seoul: Korea Institute for National Unification, 2008).

Structure

The Ministry of People's Security (MPS) has its headquarters in Pyongyang. The Minister of People's Security is Gen. Choe Pu-il. Although not publicly announced, Choe took over the ministry in February 2013, replacing Ri Myong-su, who was moved to other duties.²⁹ In April 2013 at the Central Committee Plenum, he was elevated to the Politburo as an alternate member.³⁰ Shortly thereafter at the 7th Session of the 12th SPA, he was appointed a member of the National Defense Commission, replacing Ri Myong-su. Before his appointment, Choe was the first vice chief of the General Staff Department and director of the GSD's Operations Bureau.³¹ At the Third Party Conference in 2010, he was appointed to the KWP Central Military Committee. The Ministry has several vice ministers and a chief of staff who oversees several divisions and bureaus.³² The Political Bureau exists outside of the chief of staff chain of command and is responsible for various party related functions. It reports directly to the minister, as does the Ministry's Security Department.

29 "Comrade Choe Pu-il, Alternate Member of the Political Bureau," *Nodong Sinmun*, 01 April 2013.

30 While it was not announced in the North Korean media, it is presumed that Ri Myong-su was removed from the Politburo as part of this reshuffle.

31 Choe's predecessor, Ri Myong-su, had also served as director of the GSD's Operations Bureau.

32 Some of the vice ministers include: Pak Chung-gun, Paek Pong-man, Ri Yong-il, Choe Jung-hwa, Kang Yong-ho, Won Hwa-sop, Kim Chang-byok, Kim Pyo-kyong, Han Chon-ho, Kim Chol-ung, So Chun-bong, Sin Il-nam, Paek Yong-chol, Yu Yong-chol, and Ho Yong-ho. Over the years, the number of vice ministers has varied between 3 and 10. Pak Chung-gun, who as of 2004 was described as the first vice minister, allegedly handles the administrative departments within the ministry, as well as the foreign trade bureau. *North Korea Directory* (Japan: Radio Press, Inc., 2004). The other vice ministers oversee other critical bureaus within the ministry. During Chu Sang-song's 2009 trip to China, North Korean press coverage identified Kim Po-kyong as a vice minister and Ri Pyong-sam as the director of the ministry's political bureau. See Korean Central Broadcasting Station, 19 December 2009 as cited in Open Source Center (KPP20091219032006).

- **Chief of Staff Apparatus.** The position of the Chief of Staff, which is subordinate to the first vice minister, was created in 1994, following an edict from Kim Jong-il to place the ministry on a wartime status.³³ The chief of staff is the minister's senior aide and primary conduit to the headquarters apparatus.

The apparatus contains approximately 40 bureaus and offices. Some of the more important include the following: Inspection Bureau, Investigation Bureau, Resident Registration Bureau, and Preliminary Examination Bureau.

- **The Inspection Bureau** supervises the circulation of proclamations and directives and ensures that they are implemented. It also conducts routine inspections of provincial and local public security bureaus.
- **The Investigation Bureau's** duties include: criminal (general and economic) investigations and arrest, forensic analysis, and guidance and supervision of scientific investigation activities of provincial and local public security bureaus.
- **The Resident Registration Bureau** guides and supervises the tracking of North Korean citizens throughout the country. It keeps track of a citizen's resident classification and movement documents (the so-called "resident registration dossier"). It also oversees the census.

33 DPRK National Defense Commission Order Number 7 (1994).

- **The Preliminary Examination Bureau** oversees the initial investigation of criminal cases and makes the determination on how to handle them and under what jurisdiction. If cases are determined to be political in nature, they are transferred to the SSD.
 - **The Operations Bureau** manages the operational affairs of the provincial security bureaus. It also directs the civil defense at the provincial level. This includes providing shelters for the public in case of an enemy air attack, evacuating plants and enterprises, and overseeing civil defense training for the general public.
 - **The Railway Security Bureau** is responsible for the security of North Korea's railroad tunnels, bridges, rail lines, rail facilities, military supplies at rail depots, and freight and passenger trains.
 - **The People's Security Political College** (also referred to as the **University of Politics**) of the Ministry of People's Security is responsible for the education of senior cadre. In addition to the college, the ministry has a Cadre Training School, a General Training School, and an Engineering College.³⁴
- **Political Bureau.** The Political Bureau is responsible for monitoring the lives and activities of party members. The bureau consists of approximately 10 departments, led by the organization, propaganda, and cadre departments.³⁵ While the Political Bureau exists within the ministry

34 The last publicly identified president of the university was So Chun-bong. The rector is Kim Jang-kil. In October 2012, the university was renamed the Kim Jong-il People's Security University.

35 To work for the Ministry of People's Security, applicants must submit to a very thorough

chain of command, it is also under the control and guidance of the KWP Organization Guidance Department.³⁶

- **Security Department.** This department is located within the Ministry of People's Security, but reports to the SSD. Its stated purpose is to guarantee the safety of the ministry, its affiliated organizations, and personnel. Its more important mission, however, is to monitor the ministry for anti-revolutionary elements, spies, and opponents to the regime. This department also allegedly contains the Penal Affairs Bureau, which oversees both systems of prisons and detention camps. These traditional prisons (sometimes referred to as "Indoctrination Houses") are for persons convicted of common crimes.
- **Korean People's Interior Security Force (KPISF).** The ministry also has authority over the Korean People's Interior Security Force (KPISF), a national guard-like entity dedicated to quelling social unrest and suppressing domestic rebellions.³⁷ The KPISF is headed by Gen. Kim In-sik.³⁸ In April 2012, Kim was appointed vice premier at the 5th

background check, extending to six degrees of relationships. No relatives up to and including one's second cousins can have served time in a correctional center (much less have been traitors). According to one defector, background checks within the ministry have been significantly relaxed in recent years, but people who have personal or family background stemming from South Korea are not able to get positions in the Party. *2008 White Paper on Human Rights in North Korea*, op. cit.

36 The Political Department is headed by Ri Pyong-sam. The vice director is Paek Kye-ryong.

37 The KPISF assumed its current name in early 2010. Before that, it was known as the Korean People's Security Force (KPSF). The new name (*Naemu-gun*) literally means a "force to maintain internal order and stability," in contrast to its previous name (*Kyeongbi-dae*), which meant "guard and sentinel units."

38 An alternate member of the KWP Central Committee, Kim In-sik was a member of both the Kim Jong-il and Jo Myong-nok funeral committees.

Session of the 12th SPA, while Ri Pyong-sam, the director of the KPISF Political Bureau was made an alternate member of the Politburo at the Fourth Party Conference.



Gen. Kim In-sik
Commander, KPISF



Col. Gen. Ri Thae-chol
Led KPISF delegation to China in 2011



Ri Pyong-sam
Director, KPISF Political Bureau



Minister of People's Security Gen. Ri Myong-su gives the keynote speech at a rally of MPS and KPISF personnel in April 2012. Seen behind him is Col. Gen. Ri Pyong-sam, head of the MPS/KPISF Political Bureau (Photo: KCNA)



Kim Jong-un with commanding officers of the Ministry of People's Security and the KPISF on May Day 2013. (Photo: Nodong Sinmun Online, 02 May 2013)

*Organizational Chart of the Ministry of People's Security*³⁹

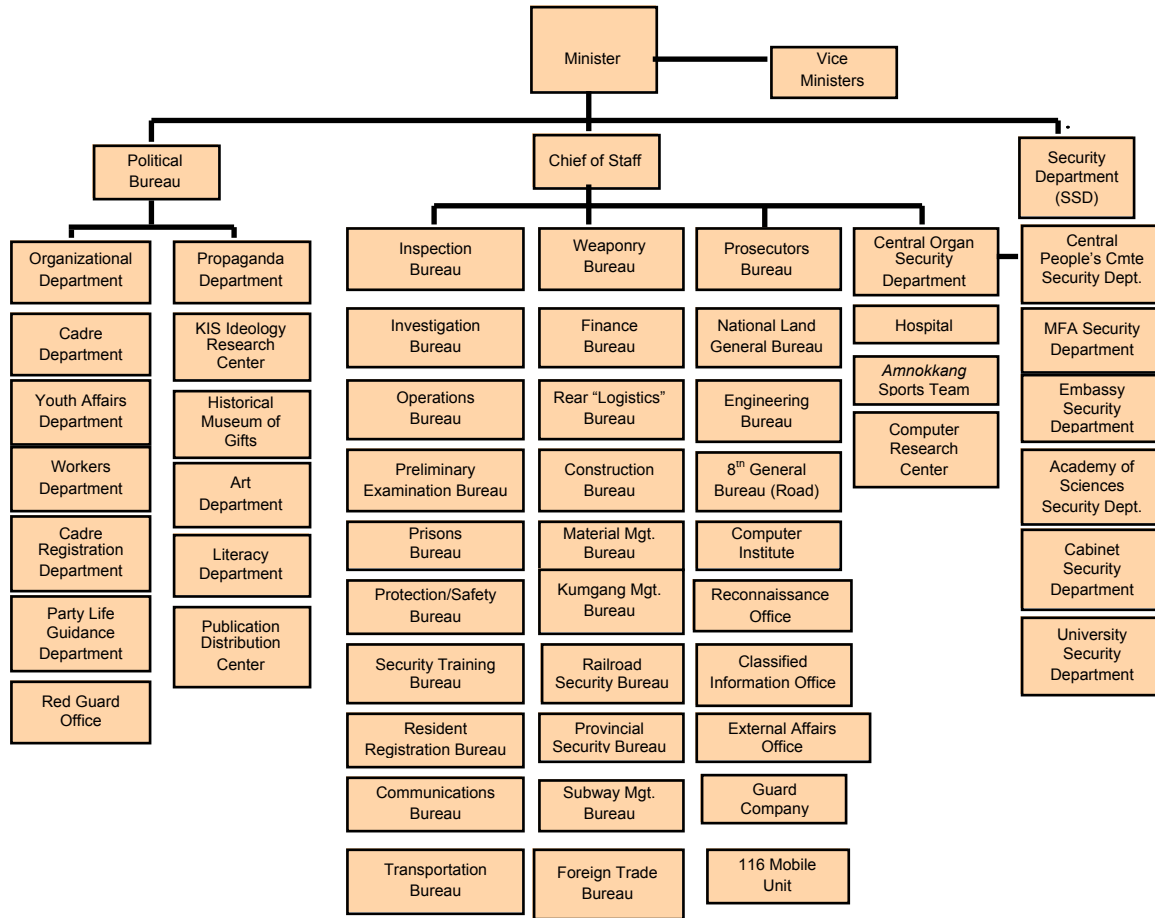

North Korea is administratively broken down into nine provinces, two municipal cities, one special city, 24 cities (*gun*), 27 districts (*guyeok*), 148 counties, two wards (*gu*), two zones (*jigu*), and 3230 villages (*ri*). The Ministry of People's Security is represented at all levels. People's Security departments exist in municipal cities,

³⁹ This chart is based on interviews and a number of sources, including Dr. So Chae-chin and Dr. Kim Kap-sik, *A Study of the North Korean Ministry of People's Security* (Seoul: Korean Institute for National Unification, 2008); Joseph S. Bermudez, Jr., *Shield of the Great Leader* (St. Leonards, Australia: Allen and Unwin, 2001); and Atsushi Shimizu, *An Overview of the North Korean Intelligence System: The Reality of the Enormous Apparatus that Supports the Dictatorship* (Tokyo, Japan: Kojin-sha, 2004).

special cities, and provinces.⁴⁰ In May 2010, the ministry revealed the existence of provincial Special Mobile Police Squads composed of 300 officers each under the authority of the provincial people's security departments. The mission of these squads is to seek out and neutralize foreign sources of negative information about the regime.

Organizational Structure of the People's Security Departments—the local offices of the MPS

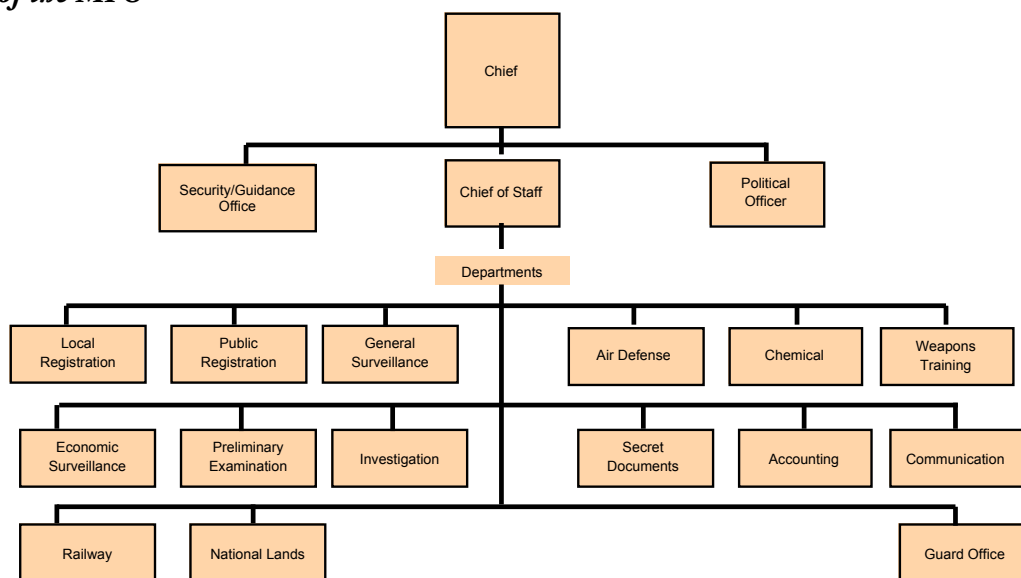

People's Security departments are the backbone of the ministry's local organization. Approximately 200 of these departments exist in the cities, counties, and districts. Security offices exist at the village level. These bureaus are headed by either a senior

⁴⁰ At the provincial level, the People's Security Department is overseen by a department chief. Underneath him are a security guidance officer and political officer. The political officer oversees the organization and propaganda offices, each headed by a secretary. The third official reporting to the chief of the People's Security Department is the chief of staff, who oversees a number of functional deputies (safety, security, citizen registration, national lands, air defense, and railway police). Of these deputies, the deputy for safety oversees the day-to-day operations of the police force, including investigations and the pretrial examinations. The chief of staff also has liaison offices for county and district public security offices.

colonel or a lieutenant colonel of police, depending on the size of the population. People's Security bureaus at each city or county and smaller substations through the country are staffed by about 100 personnel.⁴¹ The Ministry's Railroad Security Bureau also maintains work and management offices at the city and provincial levels.

⁴¹ These bureaus play an especially important role in maintaining security in the border areas. Attached to each bureau is a patrol party made up of 20 to 50 agents dedicated to capturing North Korean escapees and conducting surprise inspections.

Military Security Command (MSC)

The Military Security Command (*Bo-wi Saryeong-bu*) is the counterintelligence and counterespionage organization within the North Korean military. It is responsible for internal security within the KPA and actively seeks out elements that are corrupt, disloyal, or present a threat for a *coup d'état*. It conducts investigations, surveillance, and wiretapping of high-ranking general officers in their offices and homes.⁴² It has authority to make arrests on evidence of criminal activity or political unreliability. North Korea's police agencies cannot report to the government offices they report on. The Military Security Command, which reports officially to the MPAF up to the National Defense Commission, in the past reported directly to Kim Jong-il and presumably continues this practice under Kim Jong-un. It regularly produces reports on the ideological trends, friendships, and daily activities of general grade officers. The Minister of People's Armed Forces takes these reports, together with similar reports from the General Political Bureau, and forwards them to the Leader's personal secretariat. These reports often form the evidentiary basis of periodic purges of the armed forces. On occasion, the Military Security Command is tasked with special purpose, non-military investigations.

Aside from its police function, the Military Security Command's mandate also extends to providing security for the Leader during his visits to military units, handling the residential registration for military officers and their families, and monitoring military and civilian movements along North Korea's northern border and DMZ. Despite its broad mission set and ubiquitous presence, the Military Security Command is

⁴² According to one source, for officers over the rank of major general, either their driver or senior deputy reports to the Military Security Command. Atsushi Shimizu, *An Overview of the North Korean Intelligence System: The Reality of the Enormous Apparatus that Supports the Dictatorship*, op. cit.

He is a former political commissar of the KPA Air Force.⁴³ According to South Korean reporting, he assumed the command of the MSC in 2009 soon after Kim Jong-un was appointed heir apparent. He replaced Kim Won-hong, who is now the director of the SSD. Since Kim Jong-il's death, Cho has appeared in the North Korean media as part of Kim Jong-un's guidance inspections, most notably in March 2012 when the Supreme Commander visited Panmunjom.

The structure of the Military Security Command is fairly streamlined, especially compared to the organizational structures of the SSD and Ministry of People's Security. The day-to-day affairs of the command fall to four deputy commanders. As for the structure, the command has three overarching offices: the Cadre Department, the Political Department, and the Chief of Staff. The Cadre Department appears to have a normal human resources function, overseeing recruitment and personnel affairs. The Political Department ensures ideological loyalty and conducts a variety of indoctrination activities. The bulk of the apparatus falls under Cho's chief of staff.⁴⁴ This apparatus includes an inspection department, which conducts routine inspections of military units,⁴⁵ as well as a guard unit dedicated to providing security during the Leader's visits to military units. The organizational structure also includes a university for training agents and senior personnel within the command.⁴⁶ Much

43 Hisashi Hirai, *Kitachosen no Shidotaisei to Kokei* (Tokyo: Iwanami Shoten, 2011).

44 "Extensive Analysis of the Supreme Nerve Center of the Korean People's Army," *Shindong-A*, 01 May-01 June 2006.

45 According to defector sources, the Military Security Command until recently was in charge of conducting inspections of border units. This mission was carried out by MSC agents stationed at each brigade, squadron, and company. However, rumors of cronyism between the MSC and the border troops led to a shakeup of how border integrity was ensured. After responsibility for border security was transferred from the Ministry of People's Armed Forces to the SSD in April 2012, it is not clear if the MSC continues in this role. Presumably, this mission has been transferred to the SSD.

46 Intelligence officers in the Military Security Command graduate from the Security University under the management of the Ministry of People's Armed Forces. Until around 1983, the

of the Military Security Command's work, however, is centered on its counterintelligence departments. The number of departments varies based on sources. Some of the more important departments include the following:

- The Investigation Department, the most visible part of the Military Security Command, is in charge of conducting investigations into anti-regime activity.⁴⁷
- The Interrogation Department takes over the case once suspects have been identified by the Investigation Department.
- The General Incident Department is a senior agency within the Military Security Command that provides oversight and monitoring of the case work of the other investigative departments.

A number of other departments provide technical and administrative support to these mainly police-related departments. The Technical Department, for example, provides wiretapping and surveillance support to the Investigation Department.

education for military intelligence officers mostly took place by dispatching them for education to the SSD's Political University located in Kangso District of Nampo City. But in 1984, the Ministry of People's Armed Forces Security University was established in Mangyongdae District in Pyongyang, where it implements specialized education. The curriculum consists of such specialized areas of political subjects as intelligence, investigations, and tactics, as well as vehicle driving and taekwondo. See Yun Tae-il, *The Inside Story of the State Security Department*, op. cit.

⁴⁷ According to one defector, this department also has authority to conduct investigations abroad (presumably China) pursuant to its larger mission.



This is a photograph from the March 8, 2012 Women's Day concert. It shows Kim Won-hong and Cho Kyo'ng-chol, dressed in the new white uniforms sported by various members of the high command.

Organizational Chart of the Military Security Command⁴⁸

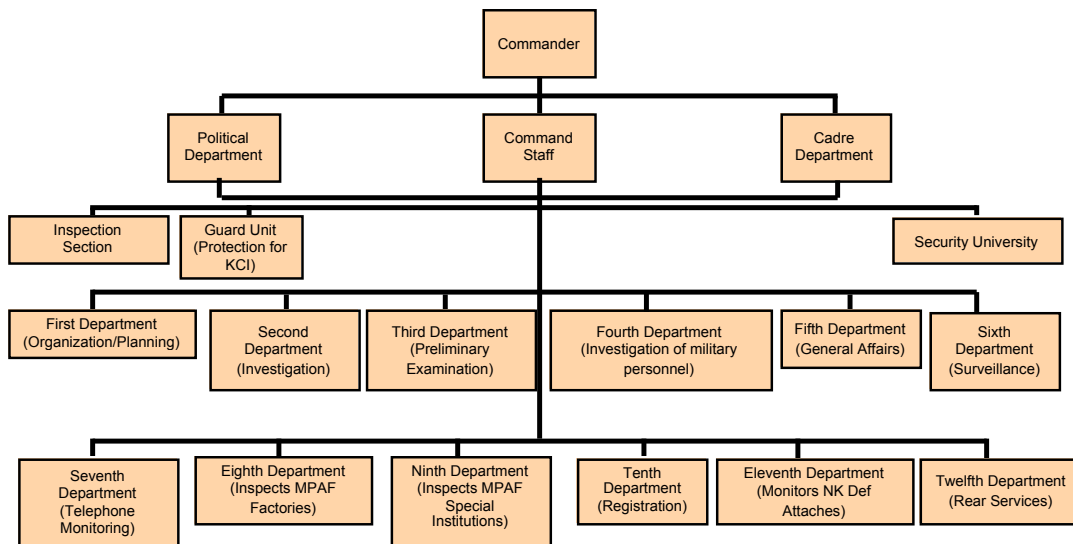

48 This chart is based on interviews and a number of sources, including Joseph S. Bermudez, Jr., *Shield of the Great Leader* (St. Leonards, Australia: Allen and Unwin, 2001) and Atsushi Shimizu, *An Overview of the North Korean Intelligence System: The Reality of the Enormous Apparatus that Supports the Dictatorship* (Tokyo, Japan: Kojin-sha, 2004).

The Military Security Command maintains agents within all critical KPA command bodies, including the General Staff and the General Political Bureau. Within the KPA itself, the Military Security Command maintains elements down to the battalion level. Each battalion has a security guidance officer. Each regiment has a senior security guidance officer and two or three security guidance officers, and each division has the departments necessary for carrying out Security Command tasks. Security guidance officers employ informants from among the soldiers, who report on spies that have infiltrated the units, rumors about the Kim family, and individual soldiers' behavior. About six or seven informants exist in any given company, which consists of about 120 soldiers.⁴⁹ In the 1990s, Kim Jong-il allowed the Military Security Command to establish offices at the provincial and city levels, thus enhancing its ability to support non-military investigations.



Kim Jong-un poses for a commemorative photograph with KPA Unit 6556. Cho Kyongchol is seated to Kim's left. (Photo: Korean Central Television, 24 May 2012)

⁴⁹ See Yun Tae-il, *The Inside Story of the State Security Department*, op. cit.

Neighborhood Watch Units (*Inminban*)

The regime's internal security system goes well beyond its bureaucratic police entities and is inculcated into the very fabric of society. Surveillance at the local level is tied to the North Korean system known as *inminban*.⁵⁰ Loosely translated as "neighborhood" or "people's group," *inminban* constitutes the lowest, "basic cell" of the North Korean social structure. Created in 1945 following Korea's liberation from Japan,⁵¹ the *inminban* was based on the Japanese "Patriot Unit" or *Ae-guk-ban*.⁵² In 1946, North Korea's "Rural, Urban and Regional People's Committee Act" obligated each *inminban* to register the number of households in its jurisdiction and identify

50 "Inmin" is North Korean (not used in South Korea) for "people" and "ban" refers to the smallest unit of organization. Literally, it means "smallest unit of the people" but structurally, it is a unit of households grouped by geographic neighborhood, so it is often translated as "Neighborhood Unit."

51 There are some scholars who argue that the *inminban* was created in 1958 as part of Kim Il-sung's efforts to consolidate his hold on the country, the so-called "five households responsibility system" (*O Ho Damdang-je*). The Five Household Unit, which lasted until 1974, refers to a system in which a fervent proponent of the regime is selected to be responsible for overseeing four other households in the rural region and was never been instituted in the city regions. Considering that the *inminban* has been referenced in Pyongyang's 17th anniversary of "Model Workers of the Neighborhood Units of North Korea's Capital City," this argument seems unlikely. See Alexander Zhebin, "North Korea's Neighborhood Unit as a Tradition Changed by Societal System," *Asean Studies*, 91st Edition (Seoul: Asia Research Center, Korea University, 1994). In addition, at least one captured North Korean document notes that in 1947, Pak Il-u, head of the Bureau of Internal Affairs, in a speech to his province chiefs, stressed that they should "examine the class background (*songbun*) and the thoughts" of all neighborhood leaders in their jurisdiction. *Sa-eop Gwan-gye Seoryu* (work documents marked "secret"), RG242, SA2005, item 6/11.

52 The Patriot Unit was instituted by Japan on July 7 1938 to effectively utilize Korean resources and mobilize the Korean people during World War II. Each unit was comprised of 10 households, conducting regular meetings and being tasked with chores in support of the war. These meetings were the gateway for the Japanese government to relay its orders and propaganda, as well as to ensure that work was done and mobilization campaigns were efficiently conducted. Another aspect of the Patriot Unit's work was to get to know each member under its control so that any suspicious activity or suspicious newcomer could be quickly identified. The Patriot Unit was more of a lower administrative unit or a police cooperative organ and when these units became the center for distribution of food in May 1940, they were turned into an important and effective means of controlling the people.

persons who belong to the neighborhood unit. The Act also called on the *inminban* to ensure that the people under its jurisdiction participate in a mandatory manner and take part in population censuses.⁵³ Today, each *inminban* generally consists of 20 to 40 households living either in a neighborhood or an apartment building.⁵⁴ Each *inminban* shares the duty of monitoring its members, providing ideological education, and serving as a conduit for various mobilization campaigns. Every North Korean citizen is required to belong to an *inminban*.

An *inminban* meets once or twice a week, attended mainly by housewives. The local party committee appoints its leader, someone with a “good” family background.⁵⁵ The group also has a designated “sanitation deputy leader,” a “household deputy leader,” and an “agitator” (concurrently the link between the *inminban* and the local party apparatus).⁵⁶

53 Chae Gyeong-hee, *A Study on Neighborhood Unit in North Korea: Focusing on Organization, Function, and Roles* (Seoul: University of North Korean Studies, dissertation thesis; December 2007).

54 If there are more than 40 to 45 families living in a designated area, there are more than one *inminban*. 40 to 60 *inminban* form one *dong*, which is one of the smallest geographical units in Korea.

55 *Inminban* heads of Pyongyang are paid a monthly salary of 70 won and given various benefits. In Hamhung, *inminban* heads are paid 30 won a month. Pyongyang's *inminban* heads wield greater influence than those in the provincial area, as people in Pyongyang might be expelled if accused by *inminban* heads. “Recollection of the North: Heads of Neighborhood Units Protect North Korea,” Democracy Network Against North Korean Gulag website, 23 March 2005.

56 The Chief of Sanitation and the Chief of Head of Households are appointed by the Chief of the *inminban*, and confirmed by the *Dong* (District) Office. Each city is broken down into precincts, which are further broken down into blocks and eventually residential areas. According to some sources, retired members of the security services are often tied into the *inminban* system in a leadership capacity. This is to ensure the full flow of intelligence back into the formal internal security structure.

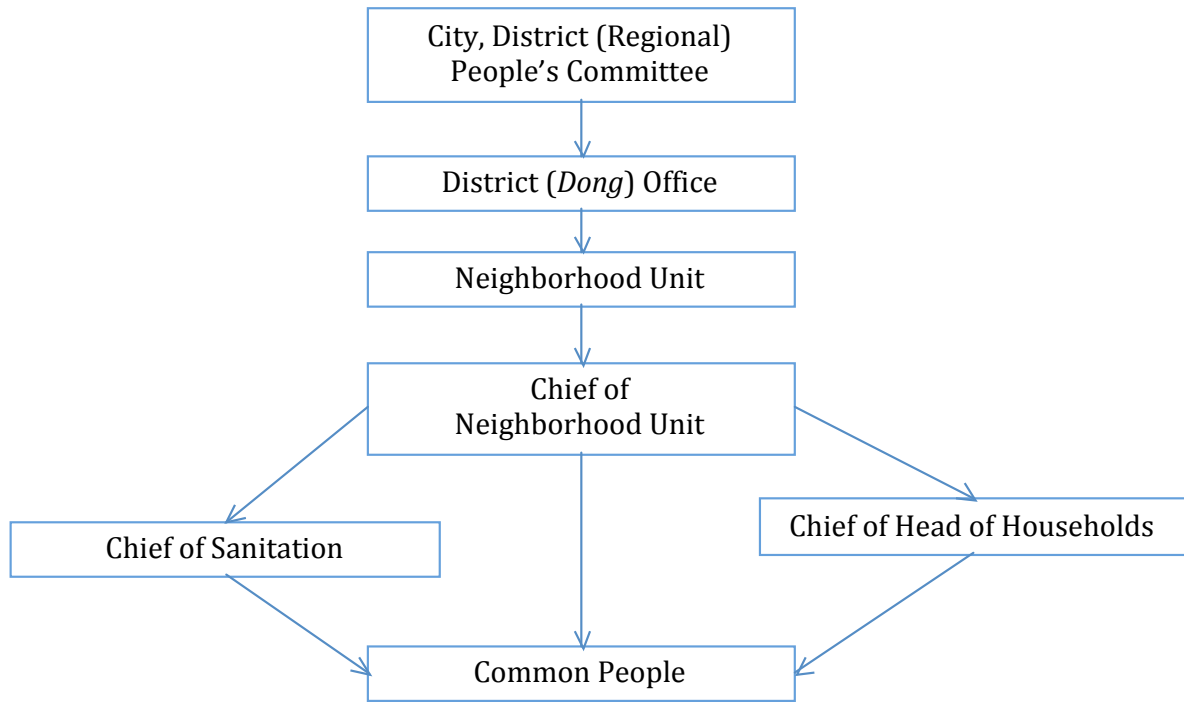
*Structural Organization of the Neighborhood Unit*⁵⁷

Administratively, the Neighborhood Unit is affiliated to the regional People's Committee but they are strictly operated under the orders of the Workers' Party. The *inminban* leader also consults frequently with agents from the State Security Department and Ministry of People's Security.⁵⁸ They closely watch the behavior and

⁵⁷ Chae Gyeong-hee, *A Study on Neighborhood Unit in North Korea: Focusing on Organization, Function, and Roles*, op. cit.

⁵⁸ The immediate supervising offices of *inminban* heads are *Dong* offices and district (city or county) people's committees. In reality, however, people's security offices and State Security Department offices hand down instructions to *inminban* heads. Every morning, *inminban* heads drop by *Dong* offices and stay there for an hour for debriefing and receiving new instructions. They again gather in the evening to report on the day's events. Once a week, they call at people's security offices to report on their duty performance and receive new instructions. They come in contact with State Security Department offices as often as need be. In terms of information, the SSD and Ministry of People's Security are focused on different areas. The SSD is most interested if an unknown person

personal relations of inhabitants under their supervision.⁵⁹ They are also granted the authority to visit homes at any time, day or night, and all guests must be reported to the *inminban*.⁶⁰ The *inminban* itself does not have any authority to solve problems; it can only report problems up the chain of command. Normally, when the problem reaches the security organs at the district level, either police or SSD agents would be sent to the neighborhood to investigate.

As can be seen from the diagram below, all *inminban* have at least one “informant” working for the SSD and at least one “police *sojowon*” working for the Ministry of People’s Security. These informants are normally chosen from among those members of the *inminban* who are at high risk according to their *songbun*. On occasion, an informant is brought in from another *inminban*.⁶¹ These informants report on any suspicious activities, from political statements made by *inminban* members, to private gatherings. They observe the neighbors’ radio and television-watching

stays with or frequents a family of a certain *inminban*. Everyone who stays overnight with friends or relatives must first register with the “people’s group” and present the necessary documents. The Ministry of People’s Security is mainly interested in people who show unusual conduct, such as an unemployed scamp or an economically suspicious person. If people do not report to work and stay at home, police come and carry them away, leaving the unfortunate dodger ignorant to the fact that their arrest was due to reporting by *inminban* heads.

59 Normally *inminban* heads are required to know details about the families under their jurisdiction, even such details as the number of bed sheets and spoons a family has. Of course, the SSD chooses people to watch the performance of *inminban* heads. This ensures that the authorities instantly know it if an *inminban* head neglects his duty or files unfaithful reports.

60 Ostensibly to prevent fires or unexpected accidents, workers must give their house keys to the *inminban* leaders. These leaders in turn visit families without notice and inspect the sanitary conditions, as well as portraits and books related to Kim Il-sung and Kim Jong-il. Moreover, during census surveys, uninvited officials from the county or city district enter and inspect houses.

61 Informants are usually chosen amongst those who have a minor weakness, such as having a relative who had defected to South Korea or a grandfather who was close to the Japanese, since members of the *inminban* would not suspect a person with such a background would be working for the SSD. This maximizes their ability to control the informant, who is already predisposed to be obedient and responsive to tasking.

habits and use of foreign currency. These informants receive a small amount of food and money from the SSD or the police, and they receive a reward for special meritorious activities.

Command and Control of the Inminban System⁶²

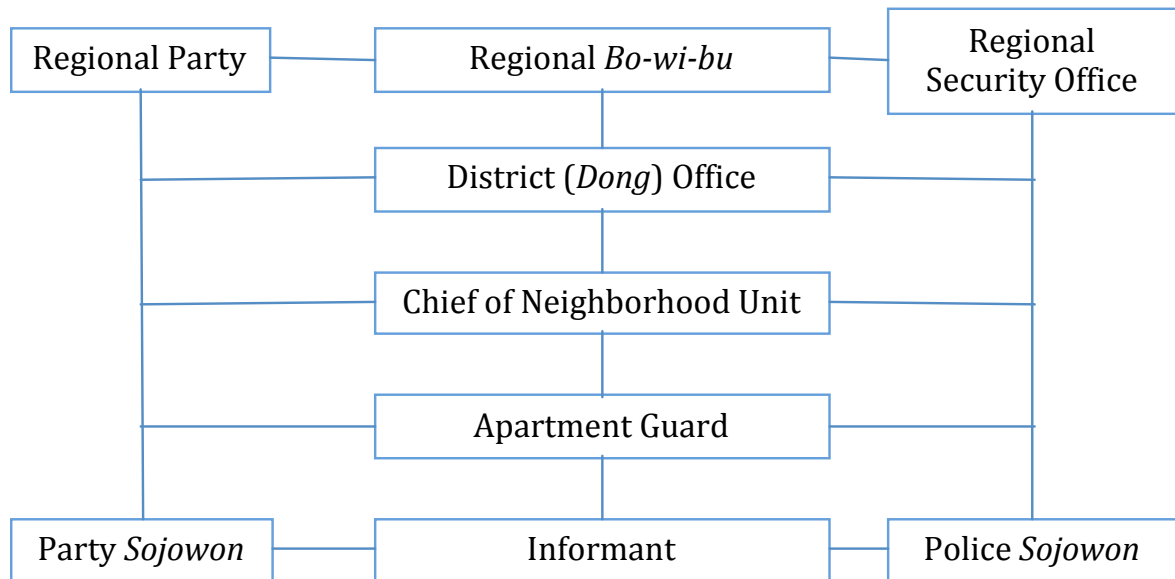

⁶² Chae Gyeong-hee, *A Study on Neighborhood Unit in North Korea: Focusing on Organization, Function, and Roles*, op. cit. “Police Sojowon” is an informant that works for the Ministry of People’s Security, whereas “Sojowon” is the official term used by the SSD for their informants

Life of an Informant (from A Prison Without Bars)

“The SSD officers in charge of a district have all official documents regarding the residents, so they know everything about an individual’s [life and family history.] We find this out by informants. We [use] this information to decide whether to arrest a person. We have many informants. There are [risks and rewards] of being an informant. If an [investigation fails or the SSD officer defects] his informants can be executed. When an informant finds something useful, that person will be compensated for his service with a mark of honor rather than money; he could be exempted from his bad family background (songbun), get a better job, or he could even be moved to Pyongyang for his safety.

“The officer picks a person with [a poor family] background or...some other flaw. The SSD officer takes the [potential informant] to his office, and beats him severely without mercy because even if the person dies, no one would even know or care about it. After the severe beatings, the officer...asks him to write down any misdemeanors he committed. [When he is done writing,] the officer yells, ‘Why did you skip over [your crimes]?’ When the officer threatens to send the person over to the MPS and says that he will receive a three to four-year sentence, then the person begs for his life and says, ‘Save me just this once, please.’ Then the officer says to him, ‘Ok, I’ll forgive you if you do something for me.’”

Source: Testimony of former SSD agent. See A Prison Without Bars: Refugee and Defector Testimonies of Severe Violations of Freedom of Religion or Belief in North Korea (Washington, DC: International Commission on Religious Freedom, March 2008).

In addition to being closely watched, the residents’ daily lives are controlled by the *inminban* to which they belong. The neighborhood association members are mobilized for patriotic duties and other mobilizations. They have to clean up local streets, collect scrap metals and bottles, polish statues and portraits of Kim Il-sung/Kim Jong-il, and attend political meetings.⁶³ According to an eyewitness testimony,

⁶³ According to one defector, a particularly disgusting responsibility of the *inminban* is the production of *bun-to* compost (produced by dehydrating human excrement and mixing it with soil) to send to the rural areas. “It was like a battle for people to produce 30 kg of *bun-to* compost per family in a severe winter. People frantically scratch the floor of their conventional toilets to collect the

We are told to assemble at someone's home at six in the evening. It means that meeting is convened. There, we are told that the Party gave us a mission; for example, a certain amount of money, a certain number of buttons, envelopes and letters for soldiers, etc. We must prepare all 'gift chests' for soldiers. Sometimes, some families are told to come up with fuel oil for boats. It is said that if you provide fuel oil, you would appear on a TV program.⁶⁴

There are many defectors who question the continued effectiveness of the *inminban*. Before the death of Kim Il-sung in 1994, the authority of *inminban* heads was quite strong and their surveillance of people was effective. As private commercial activities became widespread following the collapse of the ration system, the influence of *inminban* heads began to wane. Today, many people live in locations that are not their place of residence, which was unthinkable in the past. In the case of one association in Pyongsung, one-fourth of its members came from other places or moved out to other locations. In order to revitalize these defunct associations, North Korean authorities have rationed out small amounts of grain or daily necessities through the associations, instructing their leaders to offer them to those who faithfully attend the association. Another ploy is to provide small amounts of cash to the leaders so that

meager excrement there, meager because it is the discharge of people who are nearly starving due to the lack of food. As they eat scanty food, their discharge cannot help but be small. All residential areas were filled with the smell of human excrement that was being dried. To make things worse, *dong* offices had *inminban* compete with one another in *bun-to* production by preparing "Charts of Competition for Securing Excrement." "Recollection of the North: Heads of Neighborhood Units Protect North Korea," op. cit.

64 Chang Se-hun, "The Changing Network of City Dwellers' Social Relations." A paper presented at the annual Spring session of the North Korean Studies Association (2004).

they faithfully carry out their duties.⁶⁵ But, despite these methods of coercion and persuasion, there are stories of people resorting to bribes of *inminban* heads and security personnel to resolve disputes, *inminban* heads being killed because they showed too much “revolutionary spirit,” and *inminban* heads refusing to report many problems for fear of drawing too much attention to their neighborhood.

Ad Hoc Social Monitoring Organizations

Since the mid-1990s, the North Korean leadership has on occasion found the need to conduct intensive inspections to root out threats to the regime. For this reason, the so-called **Anti-Socialism Group** was created. Each group consists of five or six persons from the central party apparatus, augmented by the provincial party and prosecutors, and security personnel. Because they constantly conduct surveillance and investigations in various localities, looking for violations of law and order, they are reviled and feared by ordinary citizens. If these groups detain anyone (for anti-socialist behavior), it is very difficult to get released (without money to bribe or power to influence), and people are usually charged with crimes subject to “correctional labor,” which is a very serious punishment.

In 2009, defectors began to make reference to “**109 squads**” as a dedicated response to the rapid spread of illicit South Korean movies and television dramas.⁶⁶ These squads sweep through border towns at night, arresting smugglers and confiscating banned videos and music. Those convicted of sneaking contraband movies into the

65 *Ibid.*

66 “North Koreans Risking Lives For South Korean Soap Operas,” *Mainichi Shimbun*, 27 July 2009.

country face harsh penalties, including public execution in some cases.⁶⁷ It is currently unclear whether the 109 squads replaced the Anti-Socialism groups or whether they are a supplementary means of surveillance.

In addition to the more active forms of surveillance, North Korea also has passive methods for monitoring the general public, such as through various forms of guidance and education. Many of these passive forms of control are left to the country's mass social organizations. All mass organizations are guided and controlled by the party. While a number of these organizations appear concerned with the promotion of special interests, in actuality, they were founded in the early years of the KWP to serve as vehicles for the party's efforts to penetrate a broader cross section of the population.

According to Japanese and South Korean sources, there are approximately 10 to 15 of these social organizations that are well positioned to play a more internal function in controlling and monitoring North Korean society. In North Korea, all people who are not part of the Workers' Party must belong to one or more of the Party's quasi-governmental organizations. Such organizations include the Kim Il-sung Socialist Youth League, the General Federation of Trade Unions of North Korea, the Union of Agricultural Working People, the Union of Democratic Women, and the Korean Journalists Union.

The Kim Il-sung Socialist Youth League (KSYL) is the biggest and most politically active group, the only non-party member group for young people, and includes working youths, students, and military men.⁶⁸ Directly under the party Central

⁶⁷ *The 2009 White Paper on Human Rights in North Korea*, op. cit.

⁶⁸ Youths between the ages of fifteen and twenty-six are eligible to join the league regardless of other organizational affiliations, provided they meet requirements similar to those for party membership. The junior version of the youth league is the Young Pioneer Corps, open to children between the ages of nine and fifteen.

Committee, it is the only mass organization expressly mentioned in the charter of the KWP.⁶⁹ The league is the party's most important ideological and organizational training ground, with branches and cells wherever there are regular party organizations. Youth league cells exist in the army, factories, cooperative farms, schools, cultural institutions, and government agencies. The KSYL, by restricting the ideological culture and organized groups of all youths, monitors any changes in the society's way of thinking that may happen with the change of generations. It also organizes all youths to be actively involved in production, construction, and military service. The KSYL plays the important role of restricting any form of opposition groups or actions among the youths of North Korea.

KYSL members who have reached the age of 30 but have not joined the Party must join the General Federation of Trade Unions if one is a laborer or low-ranking manager, the Union of Agricultural Working People if one is a farmer, or the Union of Democratic Women if one is a housewife.⁷⁰ These workers' organizations are managed by the work departments of the committees and the KWP Central Committee. Therefore, non-Party members in North Korea receive double supervision from the organizations they belong to and from their workplace.

69 The KYSL was founded by Kim Il-sung on January 17, 1946 as the Democratic Youth League of North Korea. It was renamed the Democratic Youth League of Korea and in May 1964 renamed as the League of Socialist Working Youth of Korea. It assumed its present name on its 50th anniversary in 1996. It consists of around five million students, workers and soldiers between 14 and 30. Within the government, the KYSL coordinates the national youth policy of the Democratic People's Republic of Korea together with other youth-serving ministries, such as the Ministry of Education. The KSYL plays an important role in the planning, implementation and evaluation of this national youth policy and serves as a national youth platform to link both the governmental and non-governmental youth-related organizations and activities in this over-all national youth policy.

70 The Union of Democratic Women consists of around 200,000 women between 31 and 55 years old who do not have jobs.

In addition to their surveillance and control functions, such organizations play an important role in shaping the thinking (some would call it “brainwashing”) of the North Korean public. According to Article 4, Section 5 of the Ten Principles, everyone must “attend meetings, lectures and lessons to learn the Great Father Kim Il-sung’s revolutionary ideology and actively study the rules for more than two hours every day.” The materials for these meetings are prepared by the KWP’s Propaganda and Agitation Department. According to defectors, one of the more onerous tasks is memorization of more than 100 pages of “ideological lesson material” that have been prepared by the Propaganda and Agitation Department without getting one word wrong. This material includes Kim Il-sung and Kim Jong-il’s works, the Ten Principles for the Establishment of the One-Ideology System, *juche* ideology and related philosophical issues, documents that praise the morals and majesty of Kim Il-sung and Kim Jong-il, and various poems and songs praising the Kims. It was through these organizations that many people learned that Kim Jong-il was Kim Il-sung’s designated successor. The same thing appears to be occurring today as the public becomes acquainted with Kim Jong-un.

Leading North Korean Social Organizations

Organization	Chairman/First Secretary
Kim Il-sung Socialist Youth League	Ri Yong-chol
General Federation of Trade Unions of Korea	Kim Yong-phal
Union of Agricultural Working People of Korea	Kang Jang-uk
Korea Democratic Women’s Union	Yo Song-sil
Korean Journalists Union	Cho Chil-nam
Korean Democratic Lawyers Association	Ho Myong-kyu
Korean Bar Association	Ri Tong-sok
Korea Students Committee	Oin Chong-chol

PART II: WHAT THE INTERNAL SECURITY AGENCIES DO

1. Surveillance of North Korea's Citizens

The formal police apparatus relies on a massive, multilevel system of informants to identify critics and potential troublemakers. Entire communities are routinely subjected to security checks. Even a person's absence from work can raise the interest of the security services.⁷¹ Possessing "anti-state" material and listening to foreign broadcasts are crimes that could result in harsh punishments, including many years of labor and reeducation.⁷²

The SSD directs and maintains control over the mass surveillance networks organized across the nation. It rewards citizens who make reports with gifts. The mass surveillance networks operated by the SSD include a village (*ri*) surveillance network,⁷³ a

71 In the early 1990s, the Public Security Department (now the Ministry of People's Security) and the SSD began random checks on worker attendance in an effort to crack down on unexplained absences. Within an organization (factory, research facility, etc...), there are "special security personnel" embedded—approximately 1 security agent for every 100 to 200 people. These security agents recruit informants, who report on security issues within the organization, including absences.

72 All radio dials are fixed to the regime's official broadcasting service channels and sealed. Every three months, the Ministry of People's Security visits each home to check the seals on radios. If a seal is found broken, the owner is assumed to be guilty of listening to South Korean or other foreign broadcasting services and treated as a political criminal.

73 The village surveillance network is based on a system of the housewives or old people who live as dependents reporting to the SSD when they see suspicious people or incidents in the streets or the people's neighborhood units.

cultivated field (*bojeon*) surveillance network,⁷⁴ a school surveillance network,⁷⁵ and a student civil police unit (*mingyeong-dae*).

The SSD informant network appears to be a pyramid with agents being responsible for more informants at the lower end of the chain of command.⁷⁶ At the city and district level, the number of informants, according to one source, is nearly ten times what is needed at the provincial level. SSD personnel at the provincial level are responsible for only a handful of informants, since each case is more significant. Informants not only are responsible for reporting on their immediate surroundings, but also are often tasked by their handlers to provide surveillance on specific individuals.⁷⁷ Informants are required to report for debriefings and instructions at least on a monthly basis, and sometimes more often. The provincial SSD normally handles surveillance and monitoring of important North Korean government officials or government/research facilities.

74 The cultivated field surveillance network is an organization set up to report to the SSD at once when the workers and farmers working in the factories and rural villages near the Demarcation Line and coastal and border areas detect abnormal signs or suspicious people who are infiltrating into or fleeing from the areas.

75 The school surveillance network is a student organization for students to report any suspicious incidents they witness on the way to and from school.

76 According to Yun Dae-il, each SSD agent has 50 operatives (unofficial operatives) under his control. It is a huge organization with a combined total of about one million official and unofficial agents, suggesting that one in every 20 North Koreans is a SSD operative.

77 The main difference between the SSD and MPS informant systems is that the SSD system is more active, while the MPS system is more passive. According to defectors interviewed for this study, people work as informants because the SSD and MPS for a variety of reasons. In some cases, it is for pay and other rewards not available to the average citizen. But, in most cases, it is because the security services can provide protection in case the informant is caught for wrongdoing.

The Ministry of People's Security conducts routine, but unannounced, home inspections.⁷⁸ On occasion, the MPS's Overnight Inspection Group visits individual homes and carries out inspections between midnight and 3 AM to prevent such activities as unauthorized stays and adultery. This group frequently visits and searches homes without warning under the pretense of inspecting for illegal visitors. In other words, "bed checks" by security agents take place quite randomly.

This formal police apparatus monitors correspondence and telephone conversations. Private telephone lines operate on a system that precludes making or receiving international calls; international phone lines are available only under restricted circumstances.⁷⁹ Foreign diplomats in Pyongyang note that the local network is subdivided so phone use remains a privilege. Although a government-controlled cellular phone network exists, cell phone use for the general population, banned in 2004 and only recently reinstated, is restricted and highly monitored.⁸⁰

78 According to one source, the Ministry of People's Security personnel are often bribed to provide information on when upcoming inspections will occur.

79 Making unauthorized international phone calls can result in stiff penalties. An unauthorized call to China could elicit a significant fine, while a call to South Korea could lead to long-term incarceration in a political prison. In October 2007, a plant manager was allegedly executed for making an unauthorized international phone call. See *North Korea Today* (Seoul: Good Friends, Inc., 2007); Han Young-jin, "NSC's Detection of Cell Phone Usage is Strengthening," *Daily NK*, 16 October 2007.

80 On 15 December 2008, North Korea announced the resumption of mobile communication services through Egypt's Orascom Telecom. North Korea's mobile communication services, however, have various problems. They are limited in terms of area. Mobile communication services in North Korea are limited to Pyongyang. The call charges are also expensive, costing approximately US\$1 per minute. Calls can be made to cell phones in Pyongyang from local landline phones, but it is impossible to make calls to local landlines from the cell phones in Pyongyang. While calls can be made between cell phones and ordinary phones in Pyongyang, calls between cell phones are impossible. The reason for such incomplete cell phone calls is presumed to be connected with the lack of a wiretapping system in place. "North Korea's Abnormal Cellular Phone," *Yeolrin Bukhan Bangsong*, 09 February 2009. See also Marcus Noland, *Telecommunications in North Korea: Has Orascom Made the Connection?* (Washington, DC: Peterson Institute for International Economics, 08 September 2008).

In order to travel outside the limits of their native city or province, North Korean citizens are obliged to obtain special “travel permits” from the MPS. In order to obtain these, it is necessary to go through lengthy bureaucratic procedures. Some regions of the country, including its capital Pyongyang, are virtually closed to private visitors.

In addition to this elaborate and pervasive surveillance system, the regime also subjects its citizens to a steady diet of criticism and social manipulation. In order to systematically control people’s lives and to effectively implement Party policies, the regime requires every member of society to participate in “*chonghwa*,” self-criticism sessions with their neighbors and colleagues. These sessions are held once a week on average, serving to promulgate the latest edicts from on high, and requiring individuals to confess their shortcomings and wrong doings and criticize their neighbors. Everyone watches everyone else in order to have something to discuss in these sessions. No one knows whom to trust, even among friends, or who reports to whom.

2. Investigation and Detention

Investigation and detention are routine missions for each of North Korea's security agencies. However, high-level officials are sometimes the focus of internal security investigations and detention in North Korea. Such matters become highly regimented and require more clearly defined roles, in terms of what parts of the regime a particular security agency can investigate, than routine investigations carried out against average North Korean citizens.

- Officers of the **Ministry of People's Security** can investigate regular criminal cases at the national level, as well as at the provincial level down to the village. If an investigation involves economic crimes or the justice system, the case is normally transferred to the Procurator General's office for handling.
- The **State Security Department** is authorized to investigate "political crimes" at the national level and below. However, it cannot investigate KWP organizations in Pyongyang, the military, or the Security Command. It is, however, allowed to conduct internal affairs investigations of the Ministry of People's Security.
- The **Military Security Command** can inspect military organizations, local party organizations, and individual cadres, but it cannot investigate party branches in Pyongyang or the SSD.⁸¹

81 Detaining and arresting suspects are areas where the authority of internal security agencies has been changing. In the past, for example, the SSD and the Military Security Command needed the approval of the local party chief secretary to arrest anyone. That is apparently no longer the case. They now have the ability to detain and arrest, provided they are sure of the crimes committed. Park Hyeong-jung and Lee Kyo-duk, *Continuities and Changes in the Power Structure and the Role of Party*

- Surveillance and investigations of senior officials are reserved for the **KWP Organization Guidance Department**. Such investigations required Kim Jong-il's (and now presumably Kim Jong-un's) direct authorization. There are only three known examples of Organization Guidance Department-led investigations. The first was an investigation of the SSD in 1984, which led to the purge of Kim Pyong-ha. The second case was the so-called "*Sim-hwa-jo*" incident in 1997, which led to the removal of many of Kim Il-sung's close associates. The final case was the 2008 investigation of the KWP United Front Department, which led to the purge of several officials who oversaw South Korea policy.

In high level cases, the Ministry of People's Security and State Security Department must gain permission from the Prosecutor's office before they can apprehend a suspect. The local security office, via the provincial office, contacts the Prosecutor's Bureau in either the Ministry of People's Security or the SSD in Pyongyang, which makes a decision on the matter.

For routine cases, the North Korean Criminal Procedure Act provides some information on how cases are supposed to be conducted.⁸² As soon as a suspect has been apprehended, he undergoes interrogation for up to ten days (longer if the Prosecutor's office approves). When charges are confirmed, the investigator submits the case to a pretrial examination and the suspect is transferred from a city jail to a provincial

Organizations Under Kim Jong-Il's Reign. KINU Studies Series 0505 (Seoul: Korean Institute for National Unification, May 2005).

82 According to defector testimony, the procedures laid out in the Criminal Procedure Act are often not adhered to by investigating agencies, especially if the case is political in nature.

detention facility (either a Ministry of People's Security or SSD facility depending on whether the crime is deemed political or not) to await the pre-trial examination.⁸³

The pre-trial examination is conducted by a Pretrial Examination Agency (*Ye-shim-won*),⁸⁴ a committee drawn from officials of the local party committee, court, procuracy, SSD, military, and People's Security offices. The secretary of the local party committee normally heads the committee. The purpose of this pretrial examination, which is supposed to be completed within two months,⁸⁵ is to confirm the evidence in the case and whether the suspect is criminally responsible and what jurisdiction the case is to be handled.⁸⁶ At this stage, the case is reinvestigated and if reconfirmed, the provincial security office contacts the Prosecutor's Bureau in the Ministry of People's Security, which oversees the eventual trial.

83 So-called "detention points" (*ga-mok/gu-ryu-jang*) are facilities in North Korea where suspects are held during the investigation and pretrial process. These cells are temporary facilities designed to hold suspects during the interrogation phase and those awaiting transfer to correctional centers after the trial and final court decision. Once a person has been indicted, they are moved to a temporary jail (*gu-ryu-so*), while they await trial. There are also gathering or collection facilities (*jip-kyul-so*), which are not stipulated in North Korean legal texts. They are for those detained for minor violations such as riding a train without a boarding pass. These facilities are also used to confine defectors sent back to North Korea (after having been examined by the SSD) as they transition to their home city or village.

84 According to one senior North Korean defector, this agency is also referred to as the Law Enforcement Guidance Committee. It exists at all levels of the court system. Other sources contend that this agency is linked exclusively to the prosecutor's office.

85 In many cases, the preliminary examination of the case can take up to seven or eight months.

86 North Korean law limits incarceration during investigation and interrogation to a period not to exceed two months. The period of incarceration, however, can be extended indefinitely with the approval of the Central Procurator's Office. The approval apparently is given quite freely. It is not uncommon for individuals to be detained for a year or longer without trial or charge.

For political crimes, procedures set out in the Criminal Procedure Act are generally ignored.⁸⁷ The North Korean regime is responsible for untold numbers of disappearances. According to defector reports, individuals suspected of political crimes are often taken from their homes by state security officials late at night and sent directly, without trial, to camps for political prisoners. The SSD is authorized in most political cases to determine the terms of punishment.

“Bureau 10 Targets”

North Korea’s Criminal Code has no clauses about incidents related to spreading rumors or talking about the Kim family and their sordid life that is unknown to the North Korean society. The SSD does not follow the Criminal Procedure Act in handling these incidents. Once the accused are deemed to have criticized the authority and prestige of the father and son Kim, they are executed in secret, without going through special trial procedures.

These “Bureau 10 Targets” (in reference to the SSD’s 10th Bureau, which handles investigations) and their family are the people who have not committed any acts in violation of the Criminal Code but who can be executed at any time, due to having been members of the exploiting class in the past, a fact that will remain unchanged until they die.

Source: Yun Tae-il, The Inside Story of the State Security Department, op. cit.

If the person is suspected of a politically important crime, they are taken to a SSD “Guest House,” where they are confined for an arbitrary amount of time (meaning

⁸⁷ According to a former SSD agent, “arresting people for political crimes brings with it many benefits to the agent. There is a great reward [in promotions and decorations].” Conversely, SSD agents are often “desperate because if they don’t catch two or more cases, they cannot get promoted and they might get kicked out [of the SSD].” Once arrested, procedures of examination are also often violated. According to one SSD agent, “There are no preliminary hearings when religious people get caught. [We] regard them as anti-revolutionary elements. *A Prison Without Bars: Refugee and Defector Testimonies of Severe Violations of Freedom of Religion or Belief in North Korea* (Washington, DC: International Commission on Religious Freedom, March 2008).

it can exceed the two months spelled out in the Criminal Procedure Act) until the pretrial examination is completed. Presumably, an investigation led by the Organization Guidance Department would proceed along similar lines in order to guarantee secrecy.

There is very little information available about how cases are handled within the military. Presumably, when the Military Security Command makes an arrest, the soldier is referred to a military court, and depending on the gravity of the crime, the accused is either executed or sent to a labor-training unit. The military supposedly has special detention facilities in the six political prison camps where soldiers are detained until trial. There is also a closed facility known as *Ttuk-seom* where officers arrested for anti-government activity are confined.⁸⁸

The SSD maintains detention facilities along the border with China. Two facilities in particular appear in defector testimony—the detention facilities at Onsong and Hoeryong. Numerous human rights violations are said to have taken place at these facilities where restrictions are tight and adherence to rules is strictly enforced.

When escapees are caught in China,⁸⁹ they are normally brought back to one of these facilities for initial interrogation. SSD interrogations are designed to uncover the following types of information from the suspect:

88 *2008 Whitepaper on Human Rights in North Korea* (Seoul: Korean Bar Association, 2008).

89 The SSD has an elaborate network on agents and informants in China to track down and return North Korean escapees. As food shortages led to a dramatic increase in defectors in the late 1990, the SSD, on orders from the NDC, created a Pursuit Section dedicated to searching out and arresting North Korean defectors in foreign countries. Each city- and county-level Security Department in the border areas between North Korea and China has a Pursuit Section, consisting of 30 to 40 agents in their early to mid-twenties. SSD agents often assume convenient covers, such as members of the clergy in order to trick unsuspecting religious refugees. According to one report, there are cases where the SSD has recruited real pastors as informants in China, who in turn inform on their congregation. *A Prison Without Bars: Refugee and Defector Testimonies of Severe Violations of Freedom of Religion or Belief in North Korea*, op. cit.

- The suspect's background and former profession in North Korea
- By what route the suspect crossed into China and whether the individual was helped
- How the suspect survived in China
- Whether the suspect met with any South Koreans while in China
- Whether the suspect was exposed to foreign media (e.g., news or movies) while in China

This initial interrogation normally lasts one to two weeks. At the end of the interrogation, the escapee is registered as a “repatriated North Korean,” and a decision is made upon whether to transfer him to the Ministry of People's Security or maintain him in SSD custody.⁹⁰

⁹⁰ If the person's escape is deemed a major offense (in other words, evidence exists that he was in contact with South Koreans), he will almost certainly be sent to a political prison (*kwan-li-so*). Interestingly, according to one defector, beatings do not occur at the provincial SSD because if the person dies, the case will go unsolved. *2008 White Paper on Human Rights in North Korea*, op. cit.

3. The Role of Internal Security Agencies in Trials

In the North Korean judicial process, both adjudicative and prosecuting bodies function as powerful weapons for the proletarian dictatorship. The Constitution states that justice is administered by the Central Court, Provincial or special-city level courts, the People's Court or Special Courts, and the courts are accountable to the Supreme People's Assembly or, when it is not in session, its Presidium.⁹¹

The tri-level court system consists of a Central Court, twelve provincial courts, and approximately 100 people's courts. The Supreme Court, the highest court of appeal, stands at the apex of the court system.⁹² In addition to the Supreme Court,⁹³ there are the Provincial Courts, the People's Courts, and Special Courts. In the case of special cities directly under central authority, provincial or municipal courts serve as the courts of first instance for civil and criminal cases at the intermediate level. At the lowest level are the people's courts, established in ordinary cities, counties, and urban districts.⁹⁴ Its decisions can be appealed to the Provincial Court. Lower courts

91 In terms of organizational hierarchy, the North Korean courts operate under the direction of the Supreme People's Assembly. For this reason, the infringement of judicial independence is highly possible. Article 162 of the North Korean Constitution stipulates, "The Central Court is accountable to the SPA Presidium when the SPA is in recess."

92 Created in 1948, the Supreme Court changed its name to the Central Court with the ratification of the 1972 constitution. In 2010, a North Korean website hosted in Germany posted an alleged revised version of North Korea's Constitution that appears to reflect changes reportedly made to the document at legislature session in April. Throughout the revised Constitution, all mentions of the "Central Court" observed in the 2009 Constitution were replaced with the new title "Supreme Court."

93 It is important to note that the first-ever North Korean media pronouncement in the name of the Supreme Court occurred on 09 May 2013 clarifying the legal basis for the sentencing of Kenneth Bae.

94 The courts are not alone in assuming the legal role of educating, disciplining and punishing citizens. Local people's committees, work units, and fellow compatriots have the same function. In particular, "socialist law-abiding" committees instituted in people's committees at all levels are more

usually have one judge and two people's assessors,⁹⁵ while appeals courts have three judges.⁹⁶ Although, regional people's assemblies elect the judges and people's assessors in principle, the SPA Standing Committee appoints all candidates. A special court consists of the military court which covers criminal cases under its jurisdiction.⁹⁷ The railroad courts have jurisdiction over criminal cases involving rail and water transport workers.

powerful than legal actors since they oversee the procuracy, police, and the state inspection agencies. Specifically, they check officials' abuse of power, comment on laws, disseminate legal information, supervise work units and citizens in general, apply legal sanctions or delegate some of these functions to law-enforcement agencies at their discretion. Patricia Goedde, "Law 'Of Our Own Style:' The Evolution and Challenges of the North Korean Legal System," *Fordham International Law Journal*, Vol. 27, No. 1265 (2004).

95 According to Article 157 of the Constitution and Article 9 of the Court Procedure Law, a court will consist of one judge and two "people's jury members." The people's jurors enjoy the same status as the judge. At every level of trial, these jurors may exercise a judicial right to interrogate the accused. Typically, one judge and two people's jurors participate in the sentencing. Qualifications to serve as "people's jury" are limited to "workers" such as farmers and laborers. In fact, their primary role is not to provide fair and objective trials but to rubber stamp the conviction of the accused wrongdoer. *2008 White Paper on Human Rights in North Korea*, op. cit. The trial by peers in North Korea seems to be reserved for certain crimes and transgressions: 1) failure to adhere to the Party's unitary ideology, inadequate class consciousness and revolutionary spirit; 2) neglecting the teachings of Kim Il-sung and Kim Jong-il; 3) unintentional criticism of or distortion of Party policies; 4) misdemeanor economic crimes; and 5) lax discipline and immoral behavior. See Lee Kyu-chang, et. al., "The North Korean Criminal Trial System: Characteristics and Actual Practice," op.cit.

96 The People's Courts are at the lowest level of the judicial system. They are organized at the county (*gun*) level even though they may have jurisdiction over more than one county or smaller city. They have initial jurisdiction for most criminal and civil cases.

97 The military courts have jurisdiction over all crimes committed by members of the armed forces or security organs of the Ministry of People's Security.

One of the most powerful agencies of North Korea's totalitarian system is the Procuracy, which is vested with auditing power over other state organs to ensure the strict enforcement of law. The Constitution makes the Procuracy entirely independent of "any local organs whatsoever, being solely subordinate to the Prosecutor General of the Korean People's Democratic Republic."⁹⁸ The Prosecutor General is appointed, rather than elected, by the SPA; he in turn appoints prosecutors in the provinces, cities, and counties.⁹⁹ The Procuracy structure resembles the court structure, with a Central Procuracy, Provincial and County procuracies, and a separate Military Procuracy.



Inside the Supreme Court

98 Socialist Constitution of the Democratic People's Republic of Korea, Article 94 (1992). In the supposed 2010 revisions to the Constitution, all mentions of the "Central Public Prosecutor's Office" observed in the 2009 Constitution were replaced with the new title "Supreme Prosecutor's Office."

99 A procurator's office exists in every city and county.

The 1992 Constitution guarantees judicial independence and requires that court proceedings be carried out in accordance with laws containing elaborate procedural guarantees. Article 157 of the Constitution states that “cases are heard in public, and the accused is guaranteed the right to a defense; hearings may be closed to the public as stipulated by law.”

In North Korea, judicial independence is de facto prohibited, although it is, in principle, guaranteed by its Constitution.¹⁰⁰ Structurally, the North Korean court system is placed below the Supreme People’s Assembly, the National Defense Commission, and the cabinet.¹⁰¹ Accordingly, the courts are controlled by the “guidance” of other state organizations.¹⁰² Most importantly, the independence of the courts is difficult to maintain since the judges are politically responsible for the sentences they impose.¹⁰³

The lack of judicial independence is also evidenced by Article 11 of the Prosecution Supervisory Law that stipulates “The prosecutor(s) shall supervise whether the trial or arbitration of a case is accurately deliberating and resolving the legal requirements and in a timely manner.” By the right of the prosecution to supervise all trials and arbitrations, prosecutors have authority over judicial proceedings.¹⁰⁴

100 Constitution, Art. 166 (“In administering justice, the Court is independent, and judicial proceedings are carried out in strict accordance with the law.”) available at <http://naenara.com.kp/en/great/constitution.php?14>.

101 *Ibid*; see also Constitution, Art. 168 (“The Supreme Court is accountable to the Supreme People’s Assembly and to the Presidium of the Supreme People’s Assembly when the Supreme People’s Assembly is not in session.”) available at <http://naenara.com.kp/en/great/constitution.php?14>.

102 KINU 2004, *supra* note 2, at 110.

103 *Ibid.*, 110-11.

104 KINU, *2011 White Paper on Human Rights in North Korea*, 180-81.

Kim Il-sung said, “The law is established solely for implementing and defending the policies of the Party and therefore, you cannot properly execute the law without obeying the Party leadership.”¹⁰⁵ Judges and prosecutors are politically responsible for the sentences they impose. Even lawyers for the accused receive state salaries and are assigned clients by the local lawyers’ committee.¹⁰⁶ They are required to represent the interest of the regime, and the law states their task is to explain the charges to the accused and persuade them to confess. Article 11 of the Prosecution Supervision Law stipulates, “Prosecutors are responsible for overseeing whether the laws are accurately followed during the trials and arbitrations.” In other words, the prosecution has the right to supervise all trials.

Ordinary Crimes

Little reliable information is available on specific criminal justice procedures and practices in North Korea.¹⁰⁷ Although North Korea refuses outside observation of its legal system, it is clear that the limited guarantees legally in place often are not

105 Speech delivered at a National Conference of Judicial Workers and Public Prosecutors. *Kim Il Sung Works*. Volume 12, January-December 1958. Foreign Languages Publishing House, Pyongyang, Korea, 1983.

106 The SPA Presidium has the authority to elect or transfer Central Court judges and people’s assessors, while the SPA can appoint or remove the Procurator-General and can elect or transfer the Chief Justice. The same goes for judiciary officials down to the local level. Even lawyers for the accused receive state salaries and are assigned clients by the local lawyers’ committee.

107 To date, there are no former North Korean prosecutors, judges, people’s juries or attorneys among the defectors in South Korea. For this reason, it is difficult to know the accurate picture of trial procedures in North Korea. The testimonies of defectors vary from person to person since they do not have professional knowledge about trial procedures. *2008 White Paper on Human Rights in North Korea*, op. cit.

followed in practice.¹⁰⁸ It appears that once a preliminary examination is completed, the accused and the findings are turned over to the County Court for adjudication. It would, however, be wrong to assume that all trials in North Korea are just pro forma show pieces. There are accounts of North Korean trials for ordinary criminal cases, which follow formal procedures.

In fact, the educational benefits of open trials are touted in the revised 2004 Criminal Procedure Law.¹⁰⁹ According to Kim Jong-il:

*The on-site open trial is a form of education about abiding the law. It could educate hundreds and thousands by striking down one. Properly conducted, the on-site trials could teach a lasting lesson to many people who have witnessed them.*¹¹⁰

Any pretext, however, that North Korea's court system should exist to ensure the rights of the individual or the rule of law was dispelled in the late 1950s when the legal profession was revamped as part of Kim Il-sung's consolidation of power

108 According to defector testimony, some trials proceed in accordance with the Criminal Law and the Criminal Procedure Law. For example, this appeared to be the case in the trial of Euna Lee. For many cases, the trials only take place on paper.

109 Part of the education process is achieved by instilling fear in the population. Trials are often held at places where a large number of people can attend, such as gymnasiums, markets, town halls, plazas in front of train stations, riverside parks, movie theaters, public stadiums, farmers' markets, etc...Lee Kyu-chang, et. al., "The North Korean Criminal Trial System: Characteristics and Actual Practice," op.cit.

110 Kim Jong-il, "On Improving and Strengthening the Work of Judicial Prosecutors," *The Selections of Kim Jong-il* (Pyongyang: KWP Press, 1996).

following the so-called “August Incident.”¹¹¹ On the success of this purge, one North Korean jurist wrote:

*Great achievements were recorded in the liquidation of the injurious effects of the Rightist defeatism advocated by anti-Party counterrevolutionary factionalists, who ignore the Party’s leadership over judicial institutions. Under the pretext of the independence of judges and Socialist legality, they wanted to paralyze the functioning of the dictatorship of the proletariat often assisted by the judiciary organs.*¹¹²

According to defector testimony, judicial criminal trial procedures are often violated. Many defectors have testified that they were not aware that a court hearing was even held in their case. And when trials were held, the defendant was not allowed to present testimony or rarely given the chance to examine witnesses.

North Korea does maintain an appeals system, but people are said to avoid these

111 At the Conference of Prosecutors and Judicial Administrators in April 1958, Kim Il-sung harangued against the so-called “anti-Party factionalists.” This conference led to a purge within the legal community of those jurists who advocated the “humanist approach to law” and the “democratic system of law.” This was part of Kim’s effort to consolidate his power and eliminate all opposition to the KWP, which by extension meant all opposition to him.

112 Ri Pong-gol, “Necessity and Significance of Unifying Courts and Law Enforcement Agencies,” *Minju Sa-beop* (October 1959). North Korea initially adopted Marxist-Leninist principles in the name of socialism. Briefly, Marxist-Leninist ideology claims that law is a tool of the ruling bourgeois class, and that socialist law, an altogether different species of law, is the instrument of the proletariat dictatorship. Kim Il-sung, however, preferred the Stalinist interpretation of law as a weapon to implement state policy. He criticized domestic legal reformists who wanted to follow the de-Stalinization campaign of the Soviet Union in the late 1950s. Reformists wanted to prioritize equal application of the law, thereby subordinating party policy. Kim Il-sung purged the reformists from the courts, procuracy and the Korean Workers’ Party for being tainted with a bourgeois legal consciousness.

SSD and Trials

According to a defector arrested in China and deported to North Korea in 2002, the Cheungpyong SSD sentenced him to a one year term at the No. 55 labor training camp without holding a trial and based solely on documentary evidence.

According to another defector, if a Provincial SSD discovered a political crime, it would report it to the Prosecution Bureau of the SSD headquarters in Pyongyang. If the bureau confirmed the crime, trials would be conducted in the province where the preliminary examination was conducted. A prosecutor from the Prosecution Bureau would then hand down the sentence in the name of the Central Court in a closed-door court session and in accordance with the “sentencing guidelines.” During this session, the security agency would also decide whether to imprison the criminal for life and whether the criminal’s family would also be sent with him. There are no established guidelines for making this decision, however. The prosecutor, the security agent, and other officials confer and determine the scope and duration of detention for the accused.

Source: 2007/2008 White Papers on Human Rights in North Korea.

appeals procedures because they are most likely to end up with heavier punishment as a result. Also, it would take much longer to go through the appeals procedures, which would mean a longer and more painful period of detention in jails. Under these circumstances, many prefer to forego an appeal of their case. As noted in one recent study, “The main purpose of the appeals system is not to rectify errors in the original judgment, help those who are at a disadvantage, or unify legal interpretations, but rather to oversee the extent to which judgments faithfully reflected Kim Il-sung and Kim Jong-il’s teachings and Party policy.”¹¹³

¹¹³ Lee Kyu-chang, et. al., “The North Korean Criminal Trial System: Characteristics and Actual Practice,” op.cit.

Political Crimes and Military Tribunals

So-called “anti-State crimes” committed by anti-revolutionary hostile elements in opposition to the people’s regime and the Korean Workers’ Party are treated as political crimes, and the SSD handles their investigation as well as the preliminary examination (Articles 122 and 124 of the Criminal Procedure Law). Unlike ordinary criminal cases, the provincial and major city courts function as the primary (first level) court for all political crimes (Article 127, Criminal Procedure Law). The jurisdiction on the investigation and preliminary examination is strictly defined and practiced under the criminal procedure law. If the Ministry of People’s Security or the prosecution or any other agency has arrested a spy or an anti-party, anti-system criminal, it is required to transfer the case to the SSD.¹¹⁴

In cases of “anti-State crimes,”¹¹⁵ the procedures are even more opaque. While trials of individuals charged with a political crime (if one is held at all) may pay deference to the North Korean Criminal Code and Criminal Procedure Code, legal procedures are often violated or simplified to the point that they are meaningless. These trials normally are not made public to avoid the negative impact they can have on

114 The Maram Secret Guest House in the Yongsung District of Pyongyang is notorious for ferreting out political prisoners. According to a defector who had once worked for the SSD Trade Bureau, he was arrested for allegedly using a false identity to infiltrate the State Security Department. In a safe house in Maram of Yongsung District in Pyongyang, the police allegedly interrogated and tortured him for three months before sending him to Camp 14.

115 It is not clear how someone becomes targeted for “political-ideological crimes.” Categories of people who fall into this category have changed over time. The most simplistic definition would be individuals who are considered harmful to the Kim-led system, such as anti-party and sectarian elements and anti-revolutionaries, previous landowners and pro-Japanese, the religiously active, anyone opposed to Kim Jong-il and now Kim Jong-un’s succession to power, attempted escapees and their families, and seditious people among those repatriated from Japan. Following the collapse of Eastern Europe, those who returned from overseas duties or studies and spread knowledge of what they had seen and heard abroad were also targeted.

society and residents. Defendants are not given access to a lawyer and receive little to no legal assistance. According to several defectors the SSD's Prosecution Bureau performs the court's role.¹¹⁶

As noted before, there is very little information available on military tribunals. According to defector testimony, they follow a set of trial procedures, but it is not clear if these are the procedures laid down in the Criminal Procedure Code. The court consists of a judge, a prosecutor, and a defense attorney.

Sentencing

The sentencing of a person depends on several factors, including whether the crime is political or not, the severity of the crime, and the person's class and category (*songbun*). Punishment under the North Korean penal code is classified as "basic punishment" or "additional punishment." There are four types of basic punishment: the death penalty, unlimited term of correctional labor, limited term of correctional labor, and labor training (Art. 28). The limited term sentences range from one to 15 years. The "unlimited term of correctional labor" (15 years and longer) and "labor training" were added during the 2004 penal code revision. Convicts sentenced to unlimited or limited correctional labor punishment are detained in "correctional centers" and undergo "corrections" through labor (Art. 30). The criminals sentenced to correctional punishment are typically economic or violent criminals, rather than political criminals, and would be detained in

116 According to a former SSD agent, as soon as the preliminary examination is over, a prosecutor and judge from the SSD's Prosecution Bureau in Pyongyang will come to the province and hand down the sentence. *2008 White Paper on Human Rights in North Korea*, op. cit.

the “correctional centers” managed by the “correctional bureau” of the Ministry of People’s Security.¹¹⁷

Under the 1990 penal code, punishment as a political criminal fell to those convicted of crimes such as conspiracy to topple the state, reactionary agitations and propaganda, and treason against the fatherland. If a person were convicted of “conspiracy,” he would be either executed or banished to a political prison camp (Art. 44-55 of the Penal Code). Articles 44 through 55 of the penal code allowed the court to impose heavy punishments on political and ideological criminals. More detailed classifications of anti-state crime appeared in the revised penal code of 2004. They are included in Articles 59 through 66.

- Conspiracy to topple the state
- Terrorism
- Anti-state propaganda and agitation
- Treason against the state
- Espionage
- Destruction and murder
- Armed intervention and agitation to sever foreign relations
- Hostile actions against foreigners

117 2009 *White Paper on Human Rights in North Korea*, op. cit.

The revised penal code of 2004 appears to include some improvements on the 1990 version by adding greater specification to the description of crimes.¹¹⁸ For example, the crime of “conspiracy” is described as “those who conspired or participated in a *coup d’etat*, violent civil disturbance, or raid with anti-state aims,” (Art. 59) while the crime of “espionage” would apply to “those who were not North Korean citizens, had detected, collected or provided confidential information with the aim of spying on North Korea” (Art. 63).¹¹⁹

The Penal Code was again amended in 2007 and 2009. With the adoption of the Criminal Law Annex (on General Crimes) in 2007, stricter penalties were applied to all general crimes from indefinite terms of reform through labor to the death penalty. The revision of the Penal Code in April 2009 added provisions related to regime maintenance and was characterized by harsher punishments.¹²⁰

Executions

The death penalty is handed down for certain crimes specified by the North Korean Criminal Law Procedures are in place for carrying out executions; however, it is unclear whether these procedures are followed for all public executions. In North Korea, public executions are held frequently as a warning to the people.¹²¹ The actual conditions of

118 Han In-sup, “The Contents and Meaning of Revisions of North Korea’s Penal Code, 2004,” The 93rd Monthly Seminar of North Korea Research Association, Dec. 9, 2004.

119 *2009 White Paper on Human Rights in North Korea*, op. cit.

120 Lee Kyu-chang and Chung Gwang-jin, “The North Korean Criminal Trial System: Characteristics and Practices,” KINU Research Abstract 11-05, 2011.

121 According to Amnesty International’s annual report on capital punishment around the world, the SSD had detained more than 200 people by the beginning of 2011 in a move to consoli-

public executions are only revealed fragmentarily through defector testimony. Since the 1999 revision, North Korea has raised the age limit for the death sentence from 17 to 18 years of age. This is in accordance with Article 6(5) of the International Covenant on Civil and Political Rights (ICCPR), which North Korea ratified in 1981.¹²² In spite of changes in the North Korean Penal Code in an attempt to deal with international criticism about human rights violations, capital punishment is still stipulated in many official instructions, proclamations, and other official documents.¹²³ For example, on January 5, 2008, the KWP Organization Guidance Department issued instructions on “making this year free of human trafficking.” This document makes the death sentence mandatory for anyone found participating in human trafficking.

Article 32 of the Court Sentence and Decision Implementation Law stipulates that death sentences shall be carried out by firing squad. Death sentences are usually carried out by firing squad, with nine shots normally fired, but hanging is also used as a means of execution. For those convicted of political crimes, execution is overseen by the Provincial SSD and normally takes place within two days of sentencing.

date the leadership succession of Kim Jong-un. By July, the human rights organization had received “unconfirmed” reports that North Korean authorities had either executed by firing squad or through staged traffic accidents 30 officials who had participated in inter-Korean talks or supervised bilateral dialogues with South Korea. Furthermore, the report claims that public executions, including within prison camps were believed to have taken place throughout 2011. “More Than 30 Executed in NK Last Year: Amnesty,” *The Korea Herald Online*, 27 March 2012.

122 The death penalty in North Korea is not confined to the “most serious crimes,” and thus still in violation of ICCPR Article 6(2).

123 For example, public executions are a breach of the current Penal Code.

4. The Role of the Internal Security Agencies in Prisons¹²⁴

The prison system in North Korea has been in existence since the creation of the state. Documents confiscated by the U.S. State Department during the Korean War show that one part of the North Korean gulag was set up in 1947 (the year before the establishment of the North Korean state) under Soviet occupation.¹²⁵ From the latter half of the 1950s, the camps were enlarged, and in the first half of the 1970s, the political prison camp system was fully developed into the form that exists today.

The establishment of the political prison camps was conceived by Kim Pyong-ha, who was then the head of the newly created State Security Department and carried out in 1972 under orders from Kim Il-sung.¹²⁶ Before 1972, there were special districts set aside for the internment of families of defectors to the South, the people who had worked in the South Korean police during the Korean War, and pro-Japanese collaborators and their families. These internment facilities were located

124 For a detailed account of the North Korean prison system and how it operates, see David Hawk, *Hidden Gulag*, 2nd Edition (Washington, DC: Committee on Human Rights in North Korea, 2012).

125 According to “The Process and Guidelines for Executing Forced Labor,” jointly announced by the Chiefs of Internal Affairs and Judicial Affairs of the North Korean Peoples’ Committee on October 30, 1947, there were 17 special labor camps throughout North Korea: six in North Hamgyong Province, nine in South Pyongan Province, one in North Pyongan Province, and one in Hwanghae Province. These camps were different from the present political prison camps (political prison camps) in several aspects: First, a prisoner’s term and assignment of camp were determined by trial. Second, the prisoners had limited freedom to leave the camp and receive visits by family and relatives. Prisoners could even go to the movies with permission from the superintendent. Third, the prisoners paid for their keep through their labor. Finally, their social security number and citizenship were maintained. See Haruhisa Ogawa, *Correlation between Juche Ideology and Political Prison Camps in North Korea*. Paper presented at The 1st International Conference on North Korean Human Rights and Refugees (Seoul, 1999).

126 “Defector Describes Life in DPRK Prison Camp,” *Network for North Korean Democracy and Human Rights*, 22 May 2001.

in several cities near the 38th parallel in Hwanghae Province, including: Kaesong, Kumchon, Yongyon, Jangyon, Ahnahk, Eunyool, Chiya, Jangpoong, Kaepoong, and Panmun. These alleged “criminals,” who had been convicted of anti-state crimes, were deported in cargo trains to twelve special districts to sever them completely from contact with the rest of the North Korean population. All forms of communication with the outside world, including mail, were denied to these prisoners.

Detention Camps

Detention camps are divided into “complete control districts” and the “revolutionary districts.” The former are exclusively for those given life terms. They slave in mines and at logging yards under horrible working conditions. There is no need for ideological education because they will never return to society alive.

The latter, on the other hand, are divided into family and bachelor sections. Prisoners held here might be freed depending on the outcome of reviews made after a specified period (from one to ten years). Upon release, prisoners must sign an oath not to discuss anything about their experience. Violating the oath means returning to the camp.

Source: 2007/2008 White Papers on Human Rights in North Korea.

Today, the North Korean prison system is made up of a number of different components. Convicts sentenced to unlimited or limited correctional labor punishment are detained in long-term “correctional centers” (*kyo-hwa-so*) and undergo “corrections” through labor (Art. 30). The criminals sentenced to correctional punishment are typically economic or violent criminals, rather than political criminals, and would be detained in the “correctional centers” managed by the Ministry of People’s Security’s correctional bureau. Each North Korean province contains one or more of these facilities. In addition, North Korean authorities claim that there are three so-called “rehabilitation facilities,” including the Sariwon *Kyo-hwa-so* which holds between

800 and 1,000 persons.¹²⁷ According to defector testimony, there are nine long-term prison-labor camps in North Korea.¹²⁸

- No. 1 Re-education Camp (Kaecheon, South Pyongan Province)
- No. 3 Re-education Camp (Sinuiju, North Pyongan Province)
- No. 4 Re-education Camp (Samdeung-ri, Kangdong, South Pyongan Province)
- No. 8 Re-education Camp (“Yongdam,” Wonsan City, Kangwon Province)
- No. 12 Re-education Camp (Cheongeo-ri, North Hamgyong Province)
- No. 22 “Two-Two” Re-education Camp (Oro, South Hamgyong Province)
- No. 77 Re-education Camp (Danchun, South Hamgyong Province)
- Correctional Facility (Hoeryong, North Hamgyong Province)
- Correctional Facility (Hamhung, South Hamgyong Province)

Each camp is divided into sections, which are tied to some form of labor. Depending on the skill of the person incarcerated, they are assigned to one section or another.

127 Human rights inspectors have not been able to confirm the existence of such camps.

128 David Hawk, *Hidden Gulag* (Washington, DC: U.S. Committee for Human Rights in North Korea, 2003). See also Chong Un-suk, *Kitaachosen* (Mikasa Shobo Company, 2004).

For those who have no skills, they are normally assigned to hard labor, such as work in a coal mine.¹²⁹

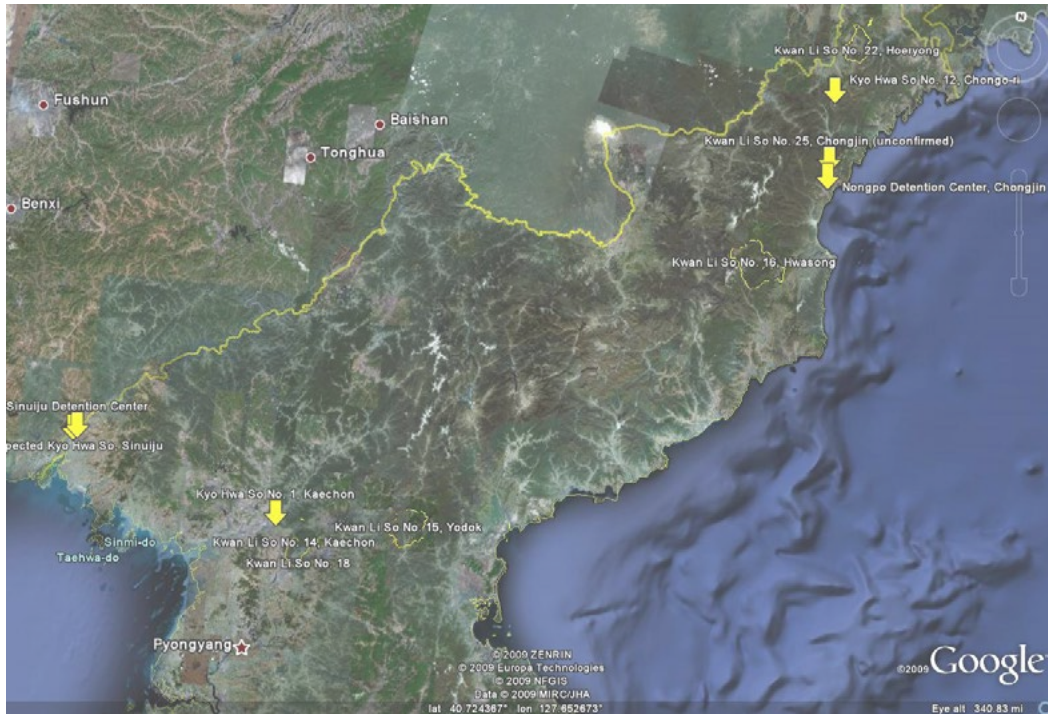

Map of some of the known political prison camps in North Korea.¹³⁰

For those awaiting preliminary investigation or are in transit to more long-term facilities, there are “collection centers.” Provincial “collection centers,” sometimes referred to as “detention centers,” (*do-jip-kyul-so*) are similar to “correctional centers.” Staff at collection centers investigate and detain defectors, people transgressing a designated area or overstaying travel without permits, those on “wanted lists,” and ordinary loafers between six months to a year—without trial and revocation of citizenship. Each

129 Discussion with North Korean defectors.

130 Google Earth map courtesy of Joshua Stanton of *One Free Korea*.

provincial government runs a “central collection center.” Anyone caught trying to escape from these central collection centers is allegedly put to death.

Throughout the provinces, there are a number of detention and interrogation facilities (*ga-mok* or *gu-ryu-jang*) for processing those repatriated to North Korea (mainly from China). Some facilities are run by the MPS and others by the SSD.¹³¹ The repatriated are then moved on to other detention/prison facilities.

*MPS-Run Detention/Interrogation Facilities*¹³²

- Chongjin, North Hamgyong Province
- Hamju District, South Hamgyong Province
- Hoeryong, North Hamgyong Province
- Haesan, Yanggang Province
- Kyongsong, North Hamgyong Province
- Musan, North Hamgyong Province
- Myungchung District, North Hamgyong Province
- Onsong, North Hamgyong Province
- Sinuiju, North Pyongan Province

131 David Hawk, *Hidden Gulag*, 2nd Edition (Washington, DC: Committee on Human Rights in North Korea, 2012).

132 *Ibid.*

*SSD-Run Detention/Interrogation Facilities*¹³³

- Chongjin, North Hamgyong Province
- Hoeryong, North Hamgyong Province
- Kyongsong, North Hamgyong Province
- Maram, Pyongyang
- Moonsu, Pyongyang
- Musan, North Hamgyong Province
- Onsong, North Hamgyong Province
- Sinuiju, North Pyongan Province

According to defectors, in addition to the correctional centers, North Korea maintains other facilities “outside” the penal code to handle minor offenders. In the late 1990s, North Korea came under heavy international criticism for its prison system, with particular focus on the number of “correctional centers.” Perhaps in response, “labor-training camps” (*Rodong Dan-ryeon-dae*) began to appear in 2001.¹³⁴ Under

133 *Ibid.*

134 According to one defector, as of August, 1995, the former *kyo-hwa-so* were abolished and new hard labor units (i.e., hard labor gangs) were organized under the control of city/county security agencies. The labor units were initially run as ad hoc organizations called “rehabilitation units,” but later each was changed into a “labor-training camp.” Each labor training camp is staffed with members from various organizations. They include one person each from the military, Ministry of People’s Security, and Inspector General’s office, one from the KWP’s three-revolution unit, one instructor from the county youth league, one troop leader, one rearguard, and a commander. See *2009 White Paper on Human Rights in North Korea*, op. cit.

the revised penal code of 2004, North Korea has installed “labor training” as a new type of punishment.¹³⁵ Labor training is a form of punishment wherein the convict is sent off to “a location” for work details. It is the sentence most given to crimes involving economic and land management, environmental protection, labor administration, and socialist culture. Sentences range from six months to two years.

*Management of North Korea’s Political Prison Camps*¹³⁶

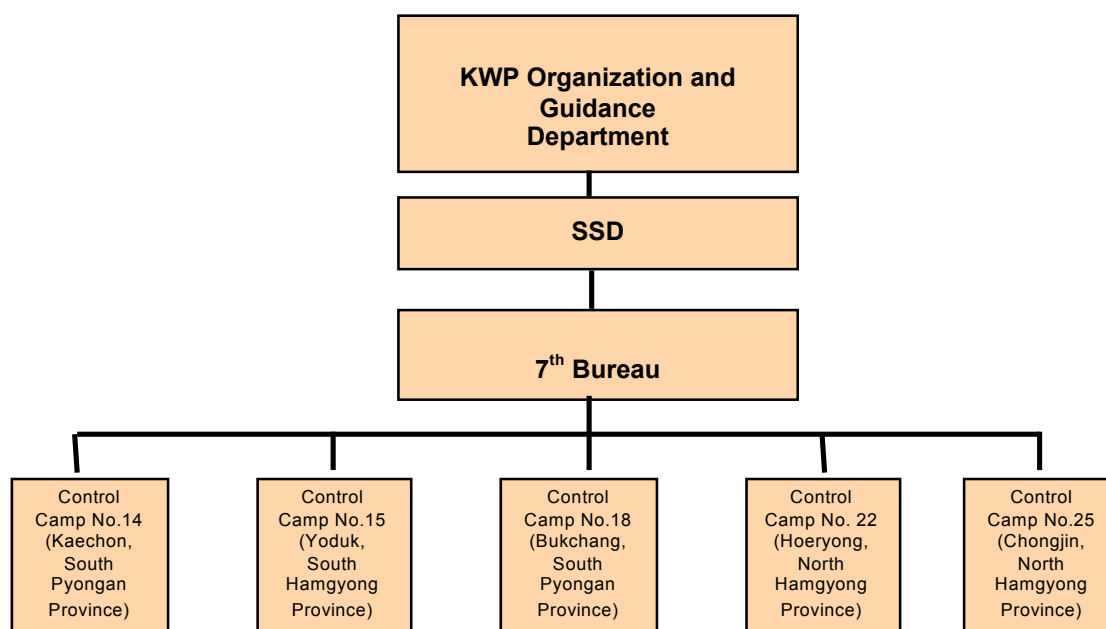

135 Labor training centers and collection centers are not official detention facilities. This in itself is a fundamental problem. The Ministry of People’s Security is solely charged with preliminary decisions to detain people either in the correctional facilities or labor training centers. In the case of the latter, people are detained without formal trials, even though the convening of trials is stipulated in North Korea’s laws. However, some defectors testified that since the Penal Code revision in 2004, people would be detained in the labor-training camps only after being sentenced by the court to serve the labor training penalty. See *2009 White Paper on Human Rights in North Korea*, op. cit.

136 *2009 White Paper on Human Rights in North Korea*, op. cit.

Political criminals are incarcerated in political penal labor colonies (*kwan-li-so*) operated by the “farm guidance bureau” of the State Security Department.¹³⁷ Popularly known as the “gulag,” these centers are political prison camps, often called “control districts” or “special districts for dictatorial control.”¹³⁸ According to recent reports, there are five of these camps in North Korea, with a total prisoner population of between 150,000 and 200,000.¹³⁹

- Political prison Camp No. 14 (Kaecheon, South Pyongan Province)
- Political prison Camp No. 15 (Yoduk, South Hamgyong Province)
- Political prison Camp No. 18 (Bukchang, South Pyongan Province)
- Political prison Camp No. 22 (Hoeryong, North Hamgyong Province)
- Political prison Camp No. 25 (Chongjin, North Hamgyong Province)¹⁴⁰

Several defector accounts point to 10 or more political prison camps, including: No. 11 (Gyongsung, North Hamkyung Province); No. 12 (Onsung, North Hamkyung Province); No. 13 (Jongsong, North Hamgyong Province);¹⁴¹ No. 16 (Hwasung,

137 At the Ministry of People’s Security, the camps that hold former high-ranking officials are also called *kwan-li-so*. Depending on the nature of the crime, these different agencies exercise control over the convicts.

138 According to one source, this network of camps is used to arbitrarily detain an estimated 0.5 to 1 percent of the country’s entire population. Christopher Green, “Camp 22 and Camp 14: Barbed Signposts for the New Kim Era,” *Sino-NK Blog*, January 2013.

139 *2008 White Paper on Human Rights in North Korea*, op. cit. See also David Hawk, *Hidden Gulag*, 2nd Edition (Washington, DC: Committee on Human Rights in North Korea, 2012).

140 According to one defector, this camp is run by the Ministry of People’s Security, not the SSD.

141 According to one North Korean defector, the No. 13 camp was the scene of human experiments in the 1980s. These experiments allegedly took place under the guidance of the SSD’s Third

North Hamgyong Province); No. 22 (Hoeryong, North Hamgyong Province); No. 26 (Seungho District, Pyongyang); No. 27 (Chunma, North Pyongan Province), and No. 105 (Danchun, South Hamgyong Province). Recent testimony, however, suggests that these camps were either closed down over the years or folded into the current camps.¹⁴² Other, more secret, camps are rumored to exist, but to date there is no hard evidence as to their location.

In March 2012, rumors began to surface through the defector network that Camp No. 22 had also been closed. According to sources, over the span of two nights, agents from the SSD sealed off the city of Hoeryong and prisoners were loaded on covered trucks and moved out of the camp to an area where they were put on freight trains (in Hoeryong) and transported south. Camp officers moved from the facility in May and by June, the camp was completely empty. One source noted that “the land Camp No. 22 was on and all the buildings have been transferred to the ownership of Hoeryong City.”¹⁴³

If in fact Camp No. 22 has been closed, the reason for its closure is not known. According to a foreign businessman who often visits the special economic zone at Rason, the closure could be related to the sale of mining or other commercial interests in the province. North Korean authorities would be keen to keep its political prisoner camps far away from its economic dealings with China. Camp No. 22 simply could have been in the way.¹⁴⁴

Bureau (preliminary investigation, now the 10th Bureau). *2008 White Paper on Human Rights in North Korea* (Seoul: Korean Bar Association, 2008).

142 *Ibid.* The *2009 White Paper on Human Rights in North Korea* suggests that these additional five camps may still be in operation and have moved to prevent their discovery from the outside world.

143 This information comes from Christopher Green, the editor of the *Daily NK Report*—provided to the author in December 2012.

144 *Ibid.* Based on recent satellite imagery, it appears that farming and mining have continued at and around Camp 22. Through the collaborative project with *DigitalGlobe* and through conducting

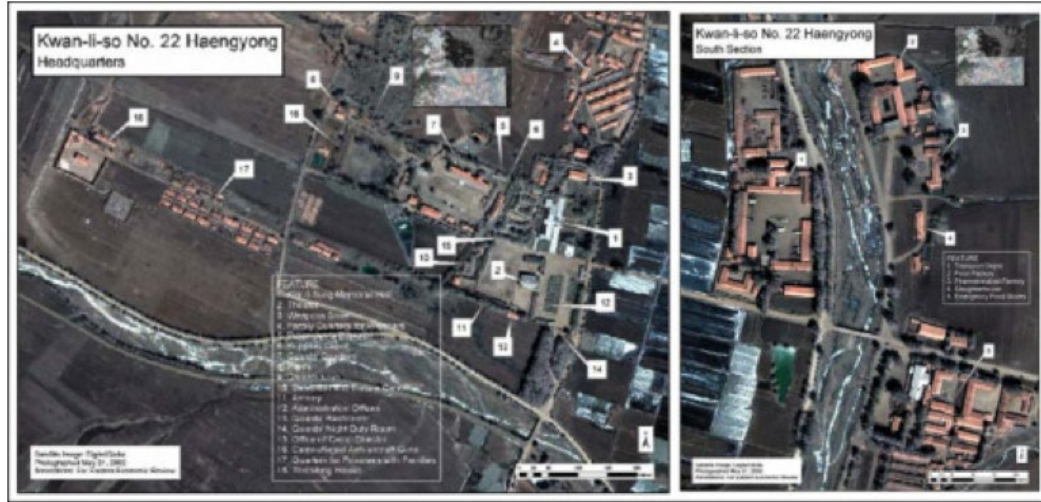

Image of Camp 22 as seen in 2002. (Photo: Google image as published on NK Now)

But as rumors spread of the closure of Camp 22, evidence of the creation of new prison camp surfaced in January 2013. Built on a compound close to the existing Camp 14, the camp is located just outside of Kaechon, South Pyongan Province. According to one source who has studied the site, the camp is surrounded by a very visible security perimeter and has two checkpoints and six guard posts. Sitting just west of Camp 14, speculation is that this camp is also a *kwan-li-so* for political prisoners.

interviews with former defectors and camp guards, HRNK is in the process of determining whether the camp has been closed, consolidated, or whether it continues to operate as a detention facility. If it has been closed, the slave labor most likely has been replaced by a more or less “regular” workforce, farmers and miners from the adjacent villages, as reported by *DailyNK* and *Radio Free Asia*.



Image of Camp 14 and the supposed new camp. (Photo: Google image as published on North Korea Economy Watch)

PART III: HISTORY OF THE INTERNAL SECURITY APPARATUS

Formative Years (1945 and 1950)¹⁴⁵

The first approximation of a North Korean government emerged with the withdrawal of the Japanese colonial administration on August 15, 1945 when Cho Man-sik set up a local government for the key province of South Pyongan, including the city of Pyongyang.¹⁴⁶ Soviet forces (25th Army), advancing down the peninsula, took over Cho's organization and founded local bodies for the maintenance of law and order called protection and security units (*bo-an-dae*).¹⁴⁷ These units were directly in charge of handling judicial and prosecutorial affairs, as well as maintaining public order.

145 This section is based on North Korean documents captured during the Korean War. It is also based on a report produced by a State Department research mission sent to Korea in October 1950 to sift through this captured material as part of a survey of how the North Korean regime operated before the outbreak of hostilities in June. The report focused on two questions: 1) In what manner and to what degree did the Soviet Union exercise control over the North Korean regime and 2) How effective was the regime in promoting stability. See *North Korea: A Case Study in the Techniques of Takeover* (Washington, DC: Department of State, 1950, released January 1961).

146 Soon after the Japanese surrender, several protection units emerged in North Korea variously known as *Chi-an-dae* (public safety unit), *Kyeong-bi-dae* (guard unit), and *Ja-wi-dae* (self-defense unit). According to one scholar, many of these "police" units were nothing more than vigilante groups. See Robert A. Scalapino and Chong Sik-lee, *Communism in Korea* (Berkeley, CA: University of California Press, 1972).

147 The 25th Army was under the leadership of Gen. I.M. Chistiakov. Maj. Gen. Romanenko was head of the Soviet Civil Administration. Col. Balasanov oversaw the construction of the police apparatus. Pang Hak-se, the future head of the secret police, was Balasanov's second in command. See Pang Irina, "Mr. Pang Hak-se: Biography of North Korea's Minister of Internal Affairs." Pang Irina was Pang Hak-se's older sister.



Cho Man-sik, who publicly opposed a four-power trusteeship of Korea, disappeared into house arrest while his fellow nationalists were rapidly eliminated from power. (Source: Wilson Center's Modern Korean History Portal)

In October, Soviet and Korean officials met to discuss how to organize North Korea's five provinces in order to administratively control the new country. This so-called Five Northern Provinces Conference achieved several outcomes. First, it created the North Korean Branch Bureau of the Korean Communist Party, known as the North Korean Communist Party. Second, it created the Five Province Administration Bureau for the oversight and management of the provinces. Third, over the course of this meeting, Kim Il-sung asserted his leadership role, wresting the Korean Communist Party leadership from the local South Korean group and from the titular head of Korean communism, Pak Hun-yung, who subsequently returned to South Korea to head its party branch. On November 19, the *bo-an-dae* were formally placed under the Five Province Administrative Bureau. Today, most North Korean organizations dedicated to internal security celebrate this date as their founding anniversary.

A central North Korean government—"The Provisional People's Committee of North Korea"—was established on February 12, 1946 under the leadership of Kim Il-sung. The Committee took over the administrative bureaus, including the Protection and

Security Bureau. This bureau, which was headed by Choe Yong-gon, a former guerilla and comrade of Kim Il-sung, was responsible for public security matters, including public safety and guarding the borders. The *bo-an-dae* in turn were subordinated to the Protection and Security Bureau, although their judicial and prosecutorial elements were carved out to create a court and procuratorial system, leaving them with public order responsibilities.¹⁴⁸ In addition to this oversight of local law enforcement organs, the Protection and Security Bureau also contained a more shadowy organization in charge of intelligence. A forerunner to the present day State Security Department (SSD), this department maintained surveillance on pro-Japanese and reactionary forces.¹⁴⁹

The Provisional People's Committee was transformed into the more permanent North Korean People's Committee in February 1947. Within this new government structure, law enforcement and internal security were the responsibility of an inter-related but separately organized triad composed of the Bureau of Internal Affairs (the former Protection and Security Bureau), the Procurator General, and the court system. In practice, these organizations functioned under cabinet direction, although the courts and procurator were, according to the constitution, outside the cabinet's administrative chain of command. Even the Bureau of Internal Affairs had a great deal of latitude and was not closely supervised by the cabinet.¹⁵⁰ This triad had considerable scope in the interpretation of criminal law and what constituted a crime or a punishable violation of state regulations.¹⁵¹

148 Hyun Joon-chon, *A Study of the Social Control System in North Korea: Focusing on the Ministry of People's Security*, op. cit.

149 This was the Department of Special Information, later renamed the Department of Political Security. *North Korea: A Case Study in the Techniques of Takeover*, op. cit.

150 The Soviet Union—through Soviet Koreans who acted as advisers to the various ministries and representatives of the Soviet political police (MGB) in North Korea—was, on the other hand, closely involved in the affairs of these organizations, especially the Bureau of Internal Affairs.

151 With the expansion and consolidation of the North Korean government and party appara-

As for the law itself, the North Korean leadership abrogated all existing Japanese laws upon the liberation of Korea in 1945, but had to reinstate the same laws to maintain public order until new laws could be promulgated.¹⁵² The new law code of 1946 included revised Japanese provisions and a Soviet-based judicial structure. Soviet advisors in North Korea played a major role in drafting the 1948 Constitution along with numerous reform laws and ordinances. North Korean judicial practice started to follow a Soviet pattern in terms of court structure and the procuracy. For example, the courts exercised not only punitive powers but also had the duty to educate criminals and the public about being faithful to the law and the party. Similar to other Communist countries, ordinary citizens served as people's assessors on the bench alongside the judge.¹⁵³

With the establishment of the Democratic People's Republic of Korea (DPRK) on September 9, 1948, the Bureau of Internal Affairs (*Naemu-guk*), which had been carrying out police and counterintelligence functions for the regime, was absorbed into a larger Ministry of Internal Affairs (*Naemu-seong*) headed by Pak Il-u.¹⁵⁴ A

tus over the next few years, the responsibilities of the internal security and law enforcement agencies increased and their organization became more complex. As the government sought to enhance its control over its territory, it expanded state regulation and instituted several policies, such as land redistribution, which were opposed by segments of the population. As a consequence, to ensure internal security, Kim Il-sung brought the police into new aspects of enforcement via-a-via both the government bureaucracy and the people.

152 The Japanese dominated the legal structure in Korea during the colonial period of 1910-1945 primarily through laws, Japanese or Japanese-trained jurists, and police surveillance. Although Japan exerted pervasive control over the Korean population via law and police power, it did not impose Japanese law completely. The Korean legal system retained many provisions not related to the maintenance of public order, for example on issues related to kinship and succession.

153 *North Korea: A Case Study in the Techniques of Takeover*, op. cit.

154 From its inception, the structure of the North Korean police system developed under strong Soviet influence, with the direct participation of Soviet security advisers dispatched by Moscow. These advisers worked in the North Korean Ministry of the Internal Affairs from its official inauguration in 1948 to the late 1950s. Hence, the early DPRK police, including the political police, was based on

massive organization of between 4,000-5,000 employees in its headquarters alone, the Ministry of Internal Affairs oversaw a network of some 12,000 regular police and 3,000 political police organized down to the village level.¹⁵⁵ In addition, it had command over an additional 45,000 employees within Security Guard units and the Border Constabulary and Railroad Guard Brigade. The functions of the ministry were wide ranging and included such diverse activities as providing for the care of orphans, beggars, and other indigents (under its Social Affairs Office), investigation of crimes, and oversight of prisons,¹⁵⁶ and supervision of political thought. To carry out these missions, the ministry was divided into four functional bureaus and two offices.

the Soviet model. Andrei Lankov, “The Repressive System And The Political Control In North Korea,” an unpublished paper based on a chapter by the same author in *Severnaia Koreia: vchera i segodnia* (Moscow: Vostochnaia literatura, 1995). It should be noted, however, that according to some reports, Pak Il-u was a representative of Mao Zedong and a member of the Yen-an faction.

155 According to North Korean documents captured during the Korean War, personnel from the Ministry of Internal Affairs were thoroughly integrated into the people’s provincial committee administrative structure. Each provincial committee staff numbered around 350, with 20 having ties to the Ministry’s security bureau. City committees had around 50 members of the Ministry of Internal Affairs on their staffs of between 140 and 185. At the county level, Ministry personnel accounted for nearly a third of the civil servants. See “North Korean People’s Committee District Administrative Staff and Duties in Province, City, and County People’s Committees,” RG242, SA2009, item 9/113 (undated, but marked “extremely secret”).

156 According to “The Process and Guidelines for Executing Forced Labor,” jointly announced by the Chiefs of Internal Affairs and Judicial Affairs of the North Korean Peoples’ Committee on October 30, 1947, there were 17 special labor camps throughout North Korea: six in North Hamkyong Province, nine in South Pyongan Province, one in North Pyongan Province, and one in Hwanghae Province. These camps were different from the present political prison camps in several aspects: First, a prisoner’s term and assignment of camp were determined by trial. Second, the prisoners had limited freedom to leave the camp and receive visits by family and relatives. Prisoners could even go to see the movies with the permission from the superintendent. Third, the prisoners paid for their keep through their labor. Finally, their social security number and citizenship were maintained. See Haruhisa Ogawa, *Correlation between Juche Ideology and Political Prison Camps in North Korea*. Paper presented at The 1st International Conference on North Korean Human Rights and Refugees (Seoul, 1999).

- Prison Bureau
- Defense Bureau (oversaw the Railroad Guard Brigade and the 3 Border Guard Constabulary brigades)
- Security Bureau (responsible for provincial Security Guard battalions and local Home Affairs offices)
- Political Security Bureau (oversaw local political/secret police)
- Military Registration Office (in charge of enforcing mobilization)
- Social Affairs Office

*Organizational Structure of the Ministry of Internal Affairs*¹⁵⁷

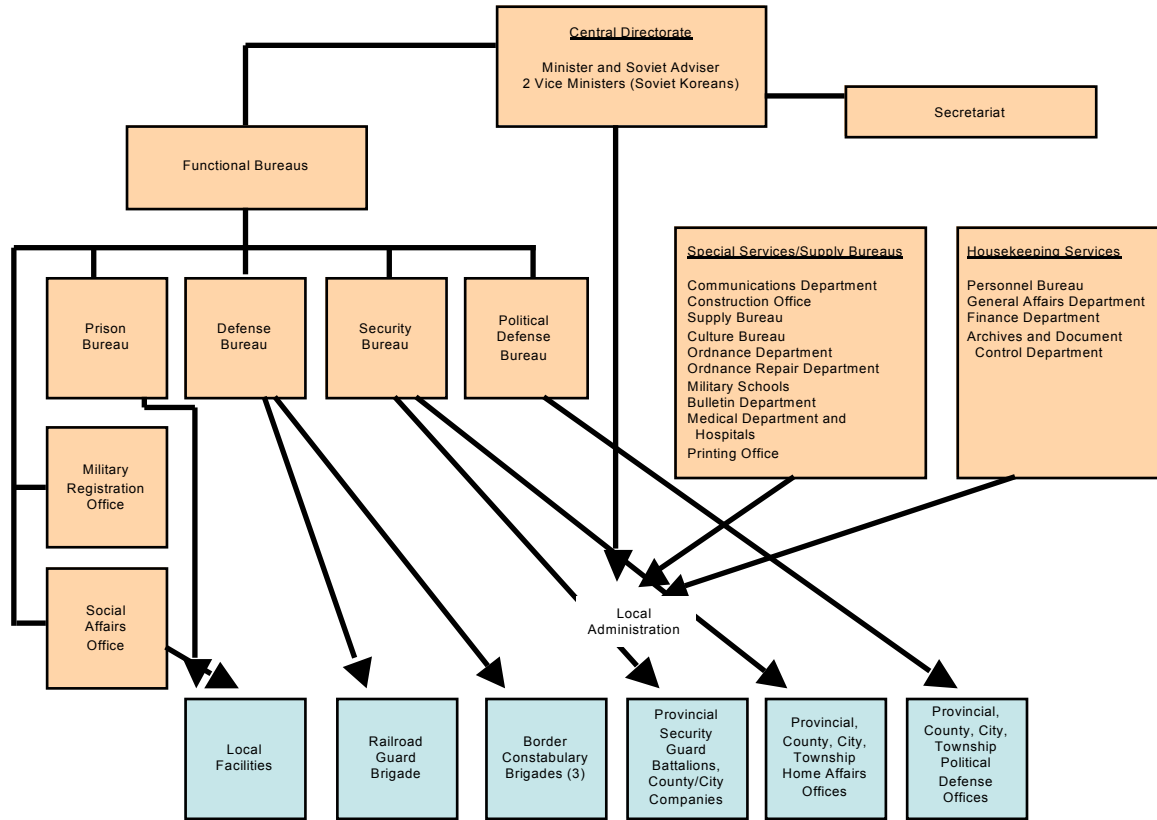

In terms of law enforcement, much of the work of the ministry’s work fell to the regular police, who were responsible for “the maintenance of public order and security” in the local villages, townships, and cities.¹⁵⁸ The police were organized along similar lines in each of the provinces. The provincial headquarters (110-125

157 *North Korea: A Case Study in the Techniques of Takeover* (Washington, DC: Department of State, 1950, released January 1961).

158 It is interesting to note that in this early period, top-down guidance for regular police recruits was to avoid “high-handedness, arrogance, selfishness, and self-aggrandizement.” They were ordered to “respect human rights,” and “beatings and torture” were forbidden. All policemen should be “models of respect for the law as a guide to the people.” See DPRK *Naemu-seong Hakseup Jaryo-jip* (materials for study, no date), RG242, SA2009, item 6/72.

personnel) oversaw city (60-70 officers) and county (40-50 officers) stations. County stations oversaw village and township (5-10 officers) stations. Provincial police chiefs reported up to the Ministry of Internal Affairs through the Security Bureau. In addition, each province had a Security Guard Battalion with companies assigned to cities and counties. The Security Guards were a mobile police reserve available for emergency situations but routinely assigned to guard factories, national buildings, and other important national facilities.¹⁵⁹

While the police at the township and village levels conducted periodic patrols as a means of enforcing law and order, as well as coordinating with the local people's committee, which was held responsible for any crimes in its jurisdiction. The police also relied on local crime fighting organizations, such as the Democratic Youth League and the Self Defense Corps, to ensure the maintenance of law and order.¹⁶⁰ Both of these groups provided a pool of informants for the police. In addition, the police posted its own dedicated informants down to the village level to collect information and conduct surveillance on specific individuals deemed potentially harmful to the state. According to one source, this informant network numbered close to 400,000 or five percent of the population by the beginning of the Korean War.¹⁶¹

159 *North Korea: A Case Study in the Techniques of Takeover*, op. cit.

160 Self Defense Units (*Ja-wi-dae*) were under the control of the Procurator General's office. Their existence dated back to Japanese rule when these units were tied into the police apparatus at the local level. But unlike their earlier incarnation, these units were not controlled by local elders, but by young, poor peasants, who were more easily swayed to do the bidding of the central authorities. The responsibilities of the Self Defense Units included the dissemination of state policy, protection against the "infiltration of reactionary elements," and security from fire and theft. "Personal History of Each Village Guard," Tongmyon Police Substation, 1949 (Top Secret). RG 242, SA 2005, 4/36. As cited in Charles K. Armstrong, *The North Korean Revolution, 1945-1950* (Cornell University Press, March 2004).

161 Discussion with North Korean defector.

Within the Ministry of Internal Affairs, enforcement of loyalty to the North Korean state was the responsibility of the Political Security Bureau. Pang Hak-se, the chief of this bureau, described its mission as exposing and destroying all manner of plots and subversive activities which are intended to destroy the newly formed North Korean government. This political or secret police had a mandate that not only paralleled some of the activities of the regular police, with which it was often in competition, but extended outside of North Korea.

The Political Security Bureau was organized into four functional offices, an interrogation office, and several administrative sections.¹⁶² The First Office was responsible for foreign espionage, counterintelligence against foreign agents, and activities abroad including surveillance of overseas Koreans. The Second Office was responsible for investigations of political parties (including the KWP), social organizations, and most government agencies, including the Ministry of National Defense.¹⁶³ The Third Office performed the same function for the Ministry of Internal Affairs and the regular police force. The Fourth Office handled investigations of national enterprises and factories for embezzlement and sabotage.¹⁶⁴

Like the regular police, the political/secret police also maintained officers in the local organs at the provincial, city, and township levels. The provincial bureau (60-80 officers) oversaw not only county and city sections (13-15 officers), but also activities related to factories. As with the regular police, much of the political police's work

162 The number of Soviet Koreans was rumored to be disproportionately higher within the Political Security Bureau than any other bureaus within the Ministry of Internal Affairs.

163 The Political Security Bureau in the Army was organized down to the battalion level. It not only maintained a watch for political dissidents, it also investigated cases of desertion and reported on troop morale, discipline, and observance of commander's orders.

164 *North Korea: A Case Study in the Techniques of Takeover*, op. cit.

focused on detecting and preventing crimes against the state and was based on an extensive informant network. The secret police network was much more extensive than that of the regular police (and may have overlapped in places).¹⁶⁵ In addition to surveillance, the Political Security Bureau used this apparatus to provide the senior leadership (beyond just Kim Il-sung) a regular check on public opinion or current and projected policies. Public opinion reports were forwarded from the county and city sections every three days. The reports, gathered from a variety of sources, reflected periodic checks on the basic attitudes of all groups of society. The leadership also used this polling function to gather likely public reaction to policy initiatives, thus giving the Political Security Bureau an input into the policy deliberation process.¹⁶⁶

Besides the police, another powerful force within the law enforcement system was the Procurator General. The powers of the procurator (also referred to as “prosecutor”), as the link between the police and the court in criminal procedure were considerable, since the procurator had both legal and actual powers to make final disposition of criminal cases with the exception of those in the jurisdiction of the Political Security Bureau.¹⁶⁷ With regard to the courts, the Procurator General held considerable influence. The appearance of the procurator in court as the state’s attorney was in itself

165 The more rudimentary informant network of the regular police relied on the posting of 3 to 10 informants in each village. These informants were normally recruited from the Youth League and were supplemented by special informants from KWP circles. Their targets of surveillance were normally people on the police’s “black list” or ex-criminals. These informants were not paid on a regular basis. The informants for the political/secret police, by contrast, were more carefully selected and highly organized. Information nets were organized in all localities, in all social organizations and government organizations, in the KWP and other parties, and in all factories and state economic establishments. These informants were paid from 1,500-2,000 won per month and received special bonuses of up to 20,000 to 30,000 won for important cases. *North Korea: A Case Study in the Techniques of Takeover*, op. cit.

166 *North Korea: A Case Study in the Techniques of Takeover*, op. cit.

167 *Ibid.*

the final indication of guilt of the accused, since the decision to prosecute generally signified guilt. Finally, the procurator performed the role of public accuser, setting in motion propaganda to instill the “proper respect” for the law.¹⁶⁸

The court system was the final stage in the administration of justice. With authority monopolized by the police and procurator, the courts were left to ratify decisions of these two agencies. The Supreme Court, appointed by the Supreme People’s Assembly, was the highest court and responsible for supervision of legal procedures, although administration of courts was handled by the Ministry of Justice. The lower courts were located at the provincial, county, and city levels. Under the Supreme Court, there were additional military, railroad, policy, and special courts. The special courts handled those political offenses tried secretly.¹⁶⁹ None of these courts had influence over the final disposition of the case, although the chief judge in the military courts participated in the findings on the case before the trial.¹⁷⁰

An almost parallel security apparatus existed within the military. Within the Ministry of Defense, the Political Defense Bureau was responsible for conducting police related investigations within the armed forces.¹⁷¹ While the Ministry of Defense provided administrative oversight of this bureau, the Political Defense Bureau took

168 Another facet of the Procurator General’s Office was its control over special bureaus in other government agencies, such as the army, railroad, and police to handle the cases brought before the special courts in these jurisdictions. The Procurator General, through the Special Procurator Bureau, also handled the prosecution of political crimes.

169 Political offenses were tried in public only if knowledge of the crime was not instructive to potential criminals or capable of inciting public disorder.

170 *North Korea: A Case Study in the Techniques of Takeover*, op. cit.

171 The Ministry of Defense’s Political Defense Bureau is the forerunner to the current Military Security Command.

operational guidance from the Ministry of Internal Affairs via the Political Security Bureau. Similarly, the Military Procurator Bureau and the Military Court Bureau appear to have had some responsibility to the Supreme Procurator and the Supreme Court, although they were also administered by the Ministry of Defense.

Therefore, by 1950, the organizational structure and procedures for regime control of the North Korean society were in place. It was pervasive, heavily influenced by Soviet advisers, and intricately tied into the North Korean leadership. Over the next several decades, the structure of the law enforcement bodies would be reorganized and Soviet influence would wane. But, in essence, the system that was put in place in these early years remains till today.

Purging the Enemies of the State (1950s and 1960s)

In March 1951, in the midst of the Korean War, Kim Il-sung reorganized the Ministry of Internal Affairs. The Political Security Bureau was reorganized and replaced by a new ministry, the Ministry of Public Security (*Sahoe An-jeon-seong*). This new ministry was created to deal with wartime problems and effectively control the opposition forces within North Korea.

Although North Korea was successful early in the war, the combined forces of South Korea and the United States conducted a counter-offensive that largely wiped out its gains by September 1950. The North Korean regime was on the verge of collapse until China intervened in October 1950. Kim Il-sung's regime was saved, but it had become a target of discontent for large segments of the North Korean population. Kim Il-sung ordered the Political Security Bureau to undertake a campaign to eradicate political prisoners during the North Korean retreat. Over 685,000 North Koreans fled south after the Chinese intervention. North Korean authorities looked on the remaining population with increasing suspicion. Many North Korean citizens were rounded up by the Political Security Bureau, found guilty by "people's courts," and executed or incarcerated.

By removing the Political Security Bureau from the Ministry of Internal Affairs, Kim Il-sung could focus more exclusively on suppressing opposition to the regime. Pang Hak-se was appointed Minister of Public Security.¹⁷² He is often described as the "founder of the North Korean security police" and the "Korean Beria."¹⁷³

172 Pang had worked in the NKVD in Uzbekistan before coming to North Korea in 1945. Pang Hak-se was a close confidant of Kim Il-sung and the founder of the North Korean secret police. A Soviet Korean, he was able to avoid the purges of the Soviet faction in the 1950s because of his ties to Kim. After leaving the Ministry of Public Security in 1960, he became the head of the Supreme Court. He lived to an old age, dying in 1992.

173 Andrei Lankov, "Pang Hak-se: Founder of NK Security Police," *Korea Times*, 22 February 2012.

After the war, Kim Il-sung's campaign to solidify control began with North Korea's first show trial in August 1953.¹⁷⁴ The trial lasted for four days. The twelve defendants before the Supreme Court were all veterans of the Communist movement who became leaders of the South Korean Workers' Party after Korean liberation. At the time of their arrest, they occupied senior posts within the North Korean regime and most were engaged in the organization and operation of guerrilla activity in the South. They were tried on four main charges: planning a coup, sabotaging the Communist movement in the South, cooperating with the Japanese police during the occupation, and conducting espionage for the United States. All of the defendants confessed. Ten were sentenced to death, and the other two were given lengthy prison sentences.¹⁷⁵

After this trial, Kim Il-sung turned his attention to the pro-Soviet and pro-Chinese factions within the North Korean leadership.¹⁷⁶ For nearly a decade, the Soviet faction had exerted influence within the regime at all levels. The "Yanan faction" benefitted from the Chinese military presence on the peninsula, which lingered even after the Armistice Agreement was signed. Both factions criticized Kim Il-sung's economic policy, which placed an emphasis on heavy industry at the expense of light industry and agriculture. Following Khrushchev's attack on Stalin's legacy at the 20th Party Congress in 1956, Kim's opponents became emboldened and began to advocate the need to take North Korea off of its wartime footing and embrace a more

174 It was also the last, since the next trial in 1955 (that of Pak Hyo-yong) proceeded without much publicity and later North Korean regime did away with show trials altogether.

175 Andrei Lankov, *From Stalin to Kim Il-Sung* (New York: Rutgers University Press, 2002).

176 Pak Il-u, the Minister of Internal Affairs, was transferred to the Ministry of Communications in 1953 and was eventually purged from the leadership in 1955. Other prominent Yanan and Soviet faction members purged between 1954 and 1956 included Choe Chang-ik (member of the Politburo and Minister of Finance), Pak Chang-ok (chairman of the State Planning Commission), and Kim Yol (member of the Politburo and chairman of the Hwanghae Provincial Party).

collective leadership. Kim pushed back, and began a series of purges of both factions, which, Kim contended, were made up of dogmatists who stood in the way of the realization of *juche*.¹⁷⁷

At the Third Party Congress in April 1956, Kim Il-sung hinted at the upcoming purge by touting the accomplishments of his partisan faction as the sole architects of the Korean communist revolutionary movement.¹⁷⁸ Kim's self-aggrandizing statements clearly indicated his desire to lead Korea along an independent path to socialism, instead of following China or the Soviet Union. Although the party Constitution of the Third Congress paid lip service to collective leadership, noting that every party organ should carry out its activities "firmly based upon Lenin's principle of collective leadership," the reshuffle of the party leadership at the end of the congress clearly indicated that the purge had begun. Of the former 67 Central Committee members selected to the Second Party Congress in 1948, only 29 were reelected to the new 71 member Central Committee. As for the senior KWP body, five of the 11 members of the new Standing Committee, which replaced the Presidium and the Politburo, were from the partisan faction, with the Yanan and Soviet factions only represented by two members each.¹⁷⁹

177 One of first victims of the purge was the leading Soviet Korean, Ho Kai. As head of the KWP's Organization Department, Ho had become the target of resentment among party members because of his arrogance. Kim took advantage of this mood to criticize Ho for the party's slow growth. Ho was censured and eventually committed suicide. In the wake of his death, Ho Kai was portrayed as a symbol of "bureaucratism" and "exclusivism" and Kim Il-sung staged a mass movement ostensibly to combat such tendencies. As a result, the KWP membership reached 1 million.

178 The partisan faction was made up of Kim's closest associates who belonged to his Manchurian guerrilla movement during the period of the Japanese occupation of Korea.

179 *Nodung Simmun*, 30 April 1956.

A month after the Congress, Kim Il-sung traveled to the Soviet Union, Mongolia, and the East European communist countries, entrusting affairs at home to his lieutenants. During his absence, secret maneuverings began among Yanan and Soviet Koreans to rally anti-Kim Il-sung forces. A campaign of criticism began culminating in the August Central Committee Plenum in which Kim was severely criticized and his policies characterized as “anti-people.”¹⁸⁰ In September, Kim prepared for a mass purge in order to completely crush the opposition to his leadership within the party, the so-called “August Factionalists.”

The Ministry of Internal Affairs was expanded and reorganized in 1956 in part to conduct the purge. Even though he was a Soviet Korean, Pang Hak-se carried out the purge.¹⁸¹ According to some sources, it was during this period that the Ministry of Defense’s Political Security Bureau, the forerunner of the Military Security Command, was created under the directorship of Sok San.¹⁸² This organization presumably took the lead in identifying and rooting out opposition within the armed forces.

The purge began with the reissuance of party identification cards to all members of the KWP, to weed out all supporters of the August revolt. But what began as a

180 Kim’s leadership was called into question because of the country’s economic problems, differences over strategies for achieving national unification, and, most importantly in the eyes of his opponents within the party, his personality cult, which continued to increase despite the new policy coming out of the Soviet Union after the CPSU’s 20th Party Congress.

181 According to Andrei Lankov, the regime ceased the use of show trials during this second widespread purge. As a consequence numerous victims disappeared without a trace and their families were forced to move or enter a prison camp. Andrei Lankov, “Pang Hak-se: Founder of NK Security Police,” *op. cit.*

182 A former Manchuria guerrilla, Sok San was close to Kim Il-sung. His status was later revealed at the Fourth Central Committee in 1961 when he was ranked 19th within the formal leadership. He would later rise to the 12th ranking.

purge of the party by 1957 evolved into a campaign to thoroughly exert the regime's control over North Korean society. This was carried out by the Ministry of Internal Affairs's Fourth Bureau, under the guidance of the KWP's Organization Department, headed by Kim Il-sung's younger brother, Kim Yong-chu.¹⁸³

In May 1957, the KWP Politburo Standing Committee adopted a resolution entitled: "On the Transformation of the Struggle with Counterrevolutionary Elements into an All-people All-Party Movement" (the so called "May 30th Resolution"). This document laid the foundation for one of the first large-scale purges in North Korean history. Unlike earlier campaigns, which were targeted against definable "enemies" (e.g. landlords, Christian missionaries, and errant party cadres) and anti-Kim elements (real and perceived), this campaign sought to evaluate the political credentials of every North Korean adult.¹⁸⁴ The whole population of North Korea was divided into three groups: "hostile forces," "neutral forces," and "friendly forces," according to one's perceived loyalty to the regime.¹⁸⁵

This was the start of North Korea's system of political caste, called *songbun*, based on who was presumed to be loyal or disloyal to the regime.¹⁸⁶ The strict division of the

183 At the local level, the Ministry of Internal Affairs coordinated with the organization departments embedded in the local party committees. According to one source, the KWP's Organization Department at the local level numbered nearly 7,000 people. *Bukhan Chonglam* (Seoul: Bukhan Yeongu-so, 1985) as cited in Andrei Lankov, "The Repressive System and the Political Control in North Korea," op. cit.

184 Andrei Lankov, *North of the DMZ: Essays on Daily Life in North Korea* (Jefferson, NC: McFarlane Publishers, 2007).

185 *Ibid.* Lankov's account of North Korea's development of the unequal hereditary groups as part of the 1957-1960 campaign is unique. Most scholars contend that North Korea began to categorize its population in the mid to late 1960s.

186 For a detailed examination of the *songbun* system, see Robert Collins, *Marked for Life: Songbun, North Korea's Social Classification System* (Washington, DC: The Committee for Human Rights in North Korea, 2012).

population into unequal hereditary groups is a defining feature of the Kim regime's system of socio-political control; it is the basic concept underlying all of North Korea's human rights violations.

During the purge, from 1957 to 1960, approximately 2,500 people were executed,¹⁸⁷ often publicly.¹⁸⁸ Many others fell victim to the Cabinet's Decree No. 149, which prohibited members of the "hostile class" from residing within 50 km of Pyongyang and Kaesong or within 20 km to any other large city. The decree also prohibited these people from residing on the border or the coastal regions. This left the inhospitable mountainous provinces, where "hostile elements" were herded into special settlements created for exiles.¹⁸⁹

By 1961, the campaign of exposing and resettling "counter-revolutionaries" had been successfully implemented. Fittingly enough, the Fourth Congress of the KWP, which met in September was hailed as the "Congress of Victors." It was dominated by Kim Il-sung's partisan faction and their loyal followers. In his report to the Congress, Kim

187 Pang Hak-se reportedly boasted to a Soviet diplomat that in 1959 alone, nearly 100,000 people were punished for political crimes. Andrei Lankov, "Pang Hak-se: Founder of NK Security Police," op. cit.

188 In the early 1960s, North Korean courts were particularly egregious in handing down death sentences. It was a transition period and it was deemed necessary to uproot any traces of former "liberalism," however relative. Andrei Lankov, "The Repressive System and the Political Control in North Korea," op. cit.

189 According to South Korean sources, under Decree No 149, which was still valid in the late 1980s, about 70,000 people had been relocated to the remote mountainous regions. *Bukhan Chonglam* (Seoul: Bukhan Yeongu-so, 1985) as cited in Andrei Lankov, "The Repressive System and the Political Control in North Korea," op. cit. These exiles were not considered to be prisoners in the strict sense. Their identification cards were marked with a special stamp; they had to show up periodically at the local police station; and could not, without a special permit, leave their settlements. Such permits could occasionally be obtained, although any trips outside the region had to be brief. It was also possible to invite people from other places to one's house. Hence, the inhabitants of the "Decree No.149 districts" were exiles rather than prisoners. Usually, they were given various manual jobs, normally very difficult.

declared that the party had succeeded in its effort to “exterminate factionalism” and had achieved “complete unity” among the rank and file members.¹⁹⁰

Kim also used the Fourth Congress to declare his independence from the Soviet Union and China. Entering the 1960s, the idea of *juche* became more concrete, expressing itself in the form of independence from the Communist bloc, a self-sufficient independent economy, and self-reliance in national defense. As a consequence, North Korea now took an openly anti-Moscow line. In a speech to the Central Committee on November 21, 1961, Kim Il-sung explicitly rejected the collective leadership principle for the first time. Although North Korea would continue to play the Soviet Union and China off against each other in an effort to secure aid, the North Korean regime now embarked on its own path in terms of internal policy.

The partisan line of the new North Korean leadership was naturally reflected in its state security apparatus. Pang Hak-se, one of the few Soviet Koreans to survive the purges of the 1950s, was himself replaced as Minister of Internal Affairs by Sok San, former head of the Political Security Bureau (*In-min-gun Jeong-chi*) of the Ministry of National Defense,¹⁹¹ a forerunner to the Military Security Command.¹⁹²

190 *Nodong Sinmun*, 12 September 1961.

191 Pang’s dismissal overlapped with a period of worsening relations between North Korea and the Soviet Union. Although never revealed, rumors suggested that his dismissal was tied to false charges he had made against other senior members of the North Korean leadership. According to one source, Pang was accused of modeling his ministry and behavior after Levrenti Beria, the notorious head of the Soviet NKVD. He was reportedly shifted to the post of assistant chief of the General Affairs Bureau with a portfolio for anti-South operations.

192 Sok San was replaced as Director of the Political Security Bureau of the Ministry of National Defense by Paek Hak-nim. Discussion with North Korean defector with knowledge of defense and security issues. Another source contends that Choe Won-sok, not Paek Hak-nim, replaced Sok San. This source contends that Paek Hak-nim was the director the Ministry of Public Security’s Security Bureau. See NKChosun biographical database.

At the Third Supreme People's Assembly in October 1962, the Ministry of Public Security was once again carved out of the Ministry of Internal Affairs. This time, however, the Ministry of Public Security assumed exclusive control over police tasks,¹⁹³ while the Ministry of Internal Affairs was given other duties. Kim Il-sung tied his own personal security apparatus (Guard Bureau) to the ministry via the appointment of his own bodyguard headed by Chon Mun-sop as a vice minister.

In 1963, Kim Il-sung began to place North Korea on an independent footing. As relations with the Soviet Union continued to deteriorate, North Korea dramatically reduced its political contacts with the East European socialist countries and the Soviet Union, and the economic aid from those countries began to dry up. At the same time, Kim instituted a policy to develop North Korea's military readiness (the Four Military Lines doctrine). This led to a decision to favor defense at the expense

193 Until 1962, the Public Security departments at the district level were called "police stations" (*naemusŏ*—literally "internal affairs stations"). Each Public Security Department was headed by either a lieutenant colonel or senior colonel. Reporting to him were four vice chiefs for political affairs, cadre affairs, economic affairs, and security affairs. Under the vice chief for security affairs was a semi-military platoon and a "People's Security Unit," which served as an auxiliary platoon.

In the countryside, a significant reorganization of the police bodies took place. In the past, substations ("police boxes") were located in the seat of the now defunct township (*myeon*), which controlled a cluster of villages (*ri*). In 1958, these substations were abolished and replaced by a resident policeman, who was assigned to each village. Approximately 20 villages made up a district.

The rationale behind the reorganization was that the new system would better facilitate the division of labor among police. The farmers were already regimented through various socio-political organizations, such as the Agricultural Workers' League, the Socialist Workers' Youth League, and the KWP, which had taken over most of the disciplinary and punitive functions traditionally performed by the police. Any problem that a resident policeman or the socio-political organizations could not handle would be transferred to the Public Security Department at the district level. See Lee Chong-sik and Kim Nam-sik, "Control and Administrative Mechanisms in the North Korean Countryside," *Journal of Asian Studies*, Vol. 29, No. 2 (1970).

of economic development, all in the service of *juche*. As a consequence, the North Korean population was armed and placed on a permanent state of mobilization.

The increasing militarist frenzy and further strengthening of Kim Il-sung's regime required a new, more detailed check on loyalty.¹⁹⁴ A new campaign began in February 1964, after the 8th Plenum of the KWP Central Committee adopted the resolution "On Further Strengthening the Work with Various Groups and Strata of the Population." This resolution envisaged a new division of the population into categories, which were more elaborate than the ones developed just seven years before. To ensure a comprehensive reach, specially appointed groups (620 groups) undertook painstaking research of every adult North Korean's family background and origin. As part of this campaign, many people were branded as sectarians or anti-revolutionaries and executed. Many others would be sent with their families to the remote mountains under Cabinet Decision No. 149.¹⁹⁵

By the mid-1960s, Kim Il-sung's mobilization of the population and continued neglect of economic development was putting the regime under increasing strain. Growing instability in China exacerbated this problem. The Great Proletarian Cultural Revolution, which Mao Zedong instigated in 1966, represented a serious threat to Kim Il-sung's autocracy. At the 14th Plenum of the 4th Central Committee held in October, Kim denounced China ideologically, without calling it by name, as

194 Kim Il-sung's distrust of the North Korean people had been brewing for years. In 1961, he and other high-ranking KWP cadre had stressed that the overwhelming majority of the population should be "re-educated." Kim himself pointed out that 99.5 percent of North Korean citizens had at least one "unreliable" relative. In November 1964, he declared that "we cannot make a revolution with young people who do not know [from experience] who a landlord or a capitalist is." Koon Won Nam, *The North Korean Communist Leadership, 1945-1965: A Study of Factionalism and Political Consolidation* (Tuscaloosa, AL: University of Alabama Press, 1974).

195 2007 *White Paper on Human Rights in North Korea* (Seoul: Korean Institute for National Unification, 2007).

practicing “left opportunism,” stimulating people with “arch-revolutionary slogans to act in extremes” and promoting “nihilist tendencies renouncing all of the past.” This would be no less dangerous for the communist movement, he declared, than the Soviet Union’s “modern revisionism.”¹⁹⁶ As the Cultural Revolution progressed, Kim was denounced in China as a “bourgeois revisionist.” China and North Korea massed troops along their Yalu River border and engaged in some minor clashes. Kim perceived himself to be in a two front war against Americans in the south and the Chinese in the north.

Kim’s growing concern for the regime’s security was reflected in the leadership changes coming out of the plenum. Among the newly elected members of the Politburo, there were six military men, including Col. Gen. Sok San as the Minister of Public Security.

Kim took advantage of this high level of war hysteria to guarantee total control of the regime. The 15th session of the KWP’s Central Committee Meeting, held in secret in the summer of 1967, addressed “Establishing the Party’s Monolithic Ideological System.” Many Central Committee members objected to this issue being placed on the agenda, arguing that it was a perpetuation and enhancement of Kim Il-sung’s cult of personality.¹⁹⁷ Opponents (from the Kapsan Group) also once again raised doubts about the wisdom of Kim’s policies and the obvious lack of economic progress. Kim

196 Evaluation of the KWP Conference from 5-12 October 1966. GDR Foreign Ministry, 18 November 1966.

197 Unlike the prior purges, this purge did not arise from a direct challenge to Kim Il-sung’s authority. The so-called Kapsan incident came about largely because several of Kim’s protégés (the Kapsan Group) opposed the rise of his younger brother, Kim Yong-chu, as heir apparent. Instead, they put forth Pak Kum-chol, the director of the KWP’s Organization Department and the fourth ranking party member, as Kim Il-sung’s successor. In addition, the Kapsan Group objected to Kim Il-sung’s continued emphasis on heavy industry, arguing that the economic budget needed to be more evenly distributed between the heavy and light industries.

succeeded in keeping the issue on the agenda, however, and in the succeeding months the KWP conducted a major ideological inspection, expelling and in many cases imprisoning Central Committee members who opposed the deification of Kim Il-sung.

The final purge of the 1960s came in response to the rising militarism Kim Il-sung had unleashed in the country. Following the Kapsan incident and the growing tension with China, North Korea's military budget soared.¹⁹⁸ As a consequence, the military's influence within the leadership began to grow and eventually several generals came together to form a clique. Led by Kim Chang-bong (Minister of National Defense) and Ho Pong-hak (Director of the KPA's General Political Bureau), this clique pushed for a more militaristic security policy, highlighted by commando strikes in South Korea and the capture of the U.S. reconnaissance ship *Pueblo*. They also sought to undermine Kim Yong-chu, who had assumed responsibility for the KWP's Organization Department after the purge of Pak Kum-chol.

A KWP inspection led by Kim Yong-chu informed Kim Il-sung in 1969 that these generals were attempting to determine military policy. Calling Kim Chang-bong and Ho Pong-hak "military bureaucrats," Kim carried out a purge of the high command. The Ministry of National Defense's Political Security Bureau ferreted out this opposition and conducted an investigation.¹⁹⁹ Kim Il-sung lauded the Political Security

198 "Kapsan" was a name given to Kim Il-sung's faction. Kapsan is the name of a place in North Korea near the border with Manchuria—as northeast China was then called—where Kim's forces were headquartered prior to escaping to the Soviet Far Eastern provinces in 1940. The "Kapsan incident" refers to Kim Il-sung's purge of this faction in the late 1960s after several generals were allegedly discovered secretly supporting Pak Kum-chol as Kim Il-sung's successor.

199 Yun Tae-il, *The Inside Story of the State Security Department* (Seoul: Monthly Chosun Publications, 2000).

Bureau for its activities.²⁰⁰ Kim changed the name of the organization to the Security Bureau and gave it more responsibility for conducting investigations.

This purge and the actions Kim Il-sung took to secure his hold on the regime dramatically impacted the state security apparatus. First, Sok San, the Minister of Public Security, was removed from his post and replaced by Kim Pyong-ha, a relative of Kim Il-sung.²⁰¹ To strengthen the party's grip over the army, Kim enhanced the KPA's General Political Bureau and sent political commissars to each regimental level of military units.²⁰²

According to the most senior defector to come out of the SSD, during the 1960s, the Ministry of Public Security's Political Security Department executed more than 6,000 of Kim Il-sung's political enemies and the hostile class and moved some 70,000 political prisoners to prison camps.²⁰³ He says that in the early 1960s only two facilities

200 It is unclear whether Paek Hak-nim was still director of the Political Security Bureau in 1969. According to one source, this bureau was headed in the late 1960s by Choe Won-sok. Choe, allegedly on the orders of Kim Yong-chu, placed Minister of National Defense Kim Chang-bong under surveillance in the run up to the purges. He also allegedly installed wiretaps in the offices and residences of other members of the Kapsan faction, including: Ho Pong-hak, Choe Kwang, Kim Chong-tae, and Chong Pyong-kap. This same source says that Kim Il-sung summoned several partisan members, including Paek Hak-nim for a meeting in which he forewarned them of the transgressions of many within the military leadership. See Masayuki Suzuki, "Establishment of the Unitary Ideology System in the Korean People's Army: The Purge of the Military Bureaucratists and Completion of the Asymmetric Strategy," in Haijme Izumi and Chang Tai-chung, eds., *Kim Seinichi Taisei no Kitachosen* (Tokyo: Keio University Press, 2004).

201 After the Kapsan affair, Kim Il-sung decided that it was necessary to have enhanced surveillance of the military beyond the General Political Bureau. The Ministry of Public Security was given license to monitor the military. Because of Sok San's involvement with the Kapsan group, he was obviously not deemed suitable to continue in his post as Minister of Public Security. Masayuki Suzuki, "Establishment of the Unitary Ideology System in the Korean People's Army: The Purge of the Military Bureaucratists and Completion of the Asymmetric Strategy," *op. cit.*

202 Before, political commissars existed at the division level, but not below.

203 Yun Tae-il, *The Inside Story of the State Security Department*, *op. cit.*

existed for political prisoners. By the end of the decade, however, the prison system had four types of prisons, each with their own level of severe punishment:

- Labor Training Center (*Nodong Danryeon-dae*) for people who committed misdemeanors
- Labor Education Center (*Nodong Kyo-yang-so*) for those sentenced over one but under two years
- Labor Correction Center (*Nodong Kyo-hwa-so*) for people who are sentenced for more than two years
- Political Prison Camp (*kwan-li-so*) for those deemed politically dangerous to the regime.

The brutality of the North Korean regime was made clear by its senior police officer, Kim Pyong-ha, in a meeting with his Soviet counterpart. Kim Pyong-ha noted that a department within the Ministry of Public Security sentenced first offenders, if they were common criminals, to two to three years of “reeducation through labor.” If they were recidivists, serious political offenders, and “traitors,” they were publicly executed after a “public revolutionary trial” or sentenced to forced labor for life.²⁰⁴

204 Balazs Szalontai, *Kim Il Sung in the Khrushchev Era: Soviet-DPRK Relations and the Roots of North Korean Despotism, 1953-1964* (Stanford, CA: Stanford University Press, 2006).

***Kimilsungism* and the Monolithic Guidance System (1970–1980)**

With the power struggles behind him, Kim Il-sung used the Fifth Party Congress in 1970 as a platform on which to begin to consolidate his hold on power and lay the foundation for the eventual succession of his son Kim Jong-il. He announced to the Party Congress that the foundation for a new, more thorough method of classifying the population had been completed. This citizen classification system, *songbun*, arranged the whole population into 51 groups under the three strata: the loyal “core” (*haeksim gyecheung*), the suspect “wavering” (*dong-yo gyecheung*), and the politically unreliable “hostile” (*jeok-dae gyecheung*).²⁰⁵ The system guaranteed that loyalty to the ruling family determined every individual’s place in society, and thereby assured that power would stay in the hands of Kim Il-sung’s family.

Kim Jong-il began to move into prominence within the KWP as his uncle, Kim Yong-chu, who had been the presumptive heir for nearly a decade, was suffering from poor health. Kim Jong-il, who had proven his talents in the party’s propaganda and organization sectors in the 1960s, was given the responsibility for organizing the Fifth Party Congress. As a consequence of the success of the Congress, which proclaimed *juche* as a monolithic ideology and laid the foundation for a dramatic expansion of his father’s cult of personality, Kim Il-sung shifted his focus to his son as the likely successor.

205 As of the most Sixth Party Congress, which was held in 1980, approximately 25 percent of the population fell into the core class, 50 percent fell into the wavering class, and the remaining 25 percent were relegated to the hostile class. Over the last 30 years, the categories have been modified; the “basic” class replaced the “wavering” class. The “wavering” class was combined with the “hostile” class to make up a new category called the “complex” class. According to the *2009 White Paper on Human Rights in North Korea*, 28 percent of the North Korean population belongs to the “core” class, 45 percent belong to the “basic” class, and 27 percent belong to the “wavering/hostile (or “complex”) class.” *2009 White Paper on Human Rights in North Korea* (Seoul: Korea Institute for National Unification, July 2009).

Kim Jong-il's rise through the KWP apparatus was accompanied by a dramatic expansion and reorganization of the regime's internal security apparatus. With the adoption of the new Constitution in 1972, the cabinet was reorganized into the Administration Council and all of the ministries were changed to departments. The Ministry of Public Security became the Public Security Department. At the same time, the Department was enlarged by the incorporation of the Border Guard Office. In February of the next year, Kim Il-sung ordered the creation of a separate secret police organization. The Public Security Department's First, Third, Seventh, and Ninth bureaus, which were related to national security, were removed to form the new State Political Security Department (*Gukga Jeongchi Bo-wi-bu*).²⁰⁶ Kim Pyong-ha became the head of this new organization, while Ri Chin-su, who had been Kim's deputy, became the new head of the Public Security Department.²⁰⁷ Paek Hak-nim, the director of the Ministry of National Defense's Security Bureau moved to the Public Security Department to become Kim Pyong-ha's deputy. Tae Pyong-yol became the new director of the Ministry of National Defense's Security Bureau.²⁰⁸

Under this new arrangement, the Public Security Department, which numbered around 180,000, carried out routine police missions, while the State Political Security Department (SPSD), which reported up to the President's office (Kim Il-sung) and had ties to the KWP chain of command (Kim Jong-il), took the lead in ensuring regime security and supporting the succession of Kim Jong-il. As such, the SPSPD

206 Kim Il-sung's decision to separate the two security agencies apparently came about from internal tensions between the two organizations. This measure was intended to prevent inter-departmental friction and to separate the respective roles of the two departments.

207 Hyun Joon-chon, *A Study of the Social Control System in North Korea: Focusing on the Ministry of People's Security*, op. cit.

208 Tae Pyong-yol was a former courier for President Kim Il-sung. He later became a member of KWP Central Committee and a deputy to the 10th SPA. It is not clear when he took over the Security Bureau. Some sources say he assumed this post in 1978.

executed a wide range of counterintelligence and internal security functions normally associated with secret police. It monitored political attitudes of the general public and high-ranking officials, searched out anti-state “saboteurs,” and administered the camps for political prisoners. Its cadre numbered around 50,000.

In September, the Central Committee appointed Kim Jong-il as KWP Secretary for Organization and Guidance, replacing Kim Yong-chu. The Organization Guidance Department was the nerve center of the party and gave Kim Jong-il a venue through which to build his power base. He was in control of the appointment process and system of inspections. It also had a strong role in managing the evolving internal security apparatus.

In February 1974, the Central Committee elected Kim Jong-il to membership in the Politburo and endorsed his selection as heir apparent. Although not publicly announced, *Nodong Sinmun*, the North Korean party newspaper, hinted at the selection in an editorial entitled: “Let the Whole Party, Nation, and People Respond to the Call of the Great Leader and the Appeal of the Party Center for Grand Construction Programs of Socialism.” This move corresponded with the announcement of “Ten Principles in Establishing Party’s Monolithic Ideological System.”²⁰⁹ These principles stipulated that:

...Although our life is one, we wish to live for the Great Leader and willingly dedicate our youth and life to the

209 The Ten Principles consists of 10 articles and 65 clauses, based on the “Four Great Principles” of “deifying Kim Il-sung’s person,” “absolute empowerment of Kim Il-sung,” “honoring Kim Il-sung’s instructions,” and “absolute obedience in executing Kim Il-sung’s instructions.” Hyun Sung-il, *A Study on the Structure of the North Korean Worker’s Party and its Control System over the Society: The 10-Point Principle for the Establishment of the Monolithic Ideology System of the Party* (August 1999).

*Great Leader. In any adverse situation, our hearts will be loyal to the Great Leader.*²¹⁰

Kim Jong-il called on North Koreans “to unconditionally accept the instructions of the Great Leader and to act in full accordance with his will.” He also demanded from party members that they “fight to the end to protect to the death the authority of the ‘party center’ [Kim Jong-il].”²¹¹

This revision of the regime’s ideology laid the foundation for the creation of a cult of personality around Kim Il-sung, often referred to as *Kimilsungism*.²¹² Extolling Kim Il-sung’s exploits as an anti-Japanese guerrilla leader during the Japanese occupation,²¹³ this mythology signified the consolidation of his power and legitimized the role of the apparatus (primarily within the Korean Worker’s Party) dedicated to enforcing his will.²¹⁴

210 *Dang-eui Yuil Sasang Chegyeo Hwakrip-ui 10 dae Wonchik* (Ten Great Principles for the Establishment of a Unique Ideological System in the Party) (Pyongyang: Choson Nodong Ch’ulp’ansa, 1983).

211 *Ibid.*

212 While the cult of the personality was institutionalized in the 1970s, there was evidence of this phenomenon by the late 1960s. The cult actually began to reach new heights after the purging incident of the Kapsan faction in 1967. Before that, the North Korean media referred to Kim Il-sung merely as the “leader of the Korean people,” but after 1967, he became known as the “leader of all international progressive movements and forces.” He began to be called “the Great Leader of mankind.” See Kim Jong-il, “*Juche Sasang Kyoyang eseo Jegi Doe-nun Myeot-gaji Munje-e Daebayeo*” (On Some Problems of Education in the Juche Idea), in *Juche Sasang Yeon-gu* (Study of the Juche Idea) (Seoul: Taebaek, 1989). The absolutism of Kim Il-sung’s power became official in 1972 when the amended DPRK constitution introduced the institution of the presidency. As President, Kim assumed the role of “head of state and a deputy of the DPRK sovereign power.” He oversaw the work of the Central People’s Committee, which is the de jure supreme institution of state power. He also assumed command of all military forces and acted as Supreme Commander of the Republic and Chairman of the National Defense Commission. See Cheong Seong Chang, *Ideologie et système en Corée du Nord* (Paris: L’Harmattan, 1997).

213 See “Unique Theory of People’s Guerrilla War in the History of War,” Korean Central News Agency (December 16, 2006).

214 It was in this period that Kim Jong-il staked his claim within the regime. He based this claim on the genealogical link to his father through Confucian notions of filial piety and ancestor

Kim Jong-il's monolithic guidance system was instituted methodically, beginning with the party and government sectors. He used a regime of inspections to force party and government cadres to obey his authority. He sent inspection teams from the KWP's Organization Guidance Department to every party and government organization. He conducted periodic purges of the party and government apparatuses to further tie officials directly to his patronage network. To the lowest level of the party, Kim mandated participation in a variety of activities (party assessment meetings), which allowed the party to scrutinize its members' public and private lives.

Central to this power-building strategy was Kim Jong-il's control of the flow of information into the party and governmental organizations. He demanded that information pass through him and all final decisions come from him. To ensure that these demands were met, Kim established his own dedicated reporting system. The reporting system was divided into two systems. One was called a "three-line and three-day" system, which meant that briefings were to be held every three days from the three lines—party, government, and the secret police. The other reporting line was a fast-track communication line going directly to Kim Jong-il via telephone or other communication means. This system was for emergency communications. Through this reporting line, Kim was able to quickly obtain information from any part of North Korean society.²¹⁵

worship of Kim as the "father" of the North Korean state. As the unofficial heir apparent, he began to establish his own ruling system, known as the monolithic guidance system, within the larger construct of *Kimilsungism*. Within this system, only Kim Jong-il had the authority to make important decisions, which, once decided, were to be implemented absolutely and completely. Under the guidance system, party cadres were supposed to act in perfect order under his leadership. Linked to the succession and the perpetuation of the Kim family dynasty, which would become official in the early 1980s, the guidance system was designed to begin the transfer of Kim Il-sung's power to Kim Jong-il.

215 Sin Kyongwan, "Gyeot-eseo bon Kim Jong-il 2 (Close to Kim Jong-il 2)," *Wolgan chungang* (July 1991).

The Ten Principles

1. We must give our all in the struggle to unify the entire society with the revolutionary ideology of the Great Leader Kim Il-sung.
2. We must honor the Great Leader comrade Kim Il-sung with all our loyalty.
3. We must make absolute the authority of the Great Leader comrade Kim Il-sung.
4. We must make the Great Leader comrade Kim Il-sung's revolutionary ideology our faith and make his instructions our creed.
5. We must adhere strictly to the principle of unconditional obedience in carrying out the Great Leader comrade Kim Il-sung's instructions.
6. We must strengthen the entire Party's ideology and willpower and revolutionary unity, centering on the Great Leader comrade Kim Il-sung.
7. We must learn from the Great Leader comrade Kim Il-sung and adopt the communist look, revolutionary work methods, and people-oriented work style.
8. We must value the political life we were given by the Great Leader comrade Kim Il-sung and loyally repay his great political trust and thoughtfulness with heightened political awareness and skill.
9. We must establish strong organizational regulations so that the entire party, nation, and military move as one under the one and only leadership of the Great Leader comrade Kim Il-sung.
10. We must pass down the great achievement of the revolution by the Great Leader comrade Kim Il-sung from generation to generation, inheriting and completing it to the end.

In 1975, Kim began to apply the monolithic guidance system to the military. After the OGD had conducted a widespread inspection of the military in the latter half of 1974 to ensure that monolithic guidance was being followed, Kim Jong-il convened a meeting of General Political Bureau's (KPA) cadres on January 1, 1975. At this meeting, he promoted the slogan "Kimilsungization of the Whole Military." He underscored that the army was subservient to the Great Leader and the party. He also stressed that the Great Leader led the revolution through the successor (i.e., Kim Jong-il). Therefore, to follow the monolithic guidance of the successor was to fulfill the will of the Great Leader. As with the party and the government, Kim established dedicated reporting lines within the military running along three different channels: the General Political Bureau, the General Staff, and the military secret police. Han Yong-ok's replacement as director of the Ministry of People's Armed Forces Security Bureau by O Yong-pang was likely tied to this campaign.²¹⁶

At the local level, Kim resorted to several means to ensure that the monolithic guidance was followed. The most prominent method was the Three-Revolution Team Movement. In 1975, Kim dispatched a group of high-ranking officials, called the Three-Revolution Guidance Teams, to local parties in order to foster economic construction.²¹⁷ The guidance teams were supposed to supervise local parties and

216 There is some confusion among sources when Han Yong-ok and O Yong-pang served as head of the Security Bureau. It appears to be in the mid-to late 1970s, but the exact dates are in question.

217 The Three-Revolution Team concept emerged from a strategy devised by Kim Il-sung in the early 1970s to deal with problems of economic development. Despite increased investment in light industry, factories were not able to make efficient use of the more technologically advanced machinery because party cadres and technicians did not know how to use them. Their knowledge was out of date. To address this issue, Kim sent university instructors and students into the factories to educate the labor force. These teams of 20 to 50 young zealots with diverse skills stayed in the factories for months educating and pushing the work force to adapt to new methods and work harder. This was the origin of the Three-Revolution Team Movement. The concept behind this movement, which harkened back to similar movements of the early 1960s, was that the complete victory of socialism could be hastened through the vigorous promotion of the ideological, technical, and cultural revolutions." According to

the Three-Revolution Teams that had been sent out years earlier by his father to the factories. While these guidance teams increased Pyongyang's control even further at the local level, it also suppressed individual creativity and motivation, thus making the economic problems the movement was supposed to solve even worse. While it may not have addressed the country's economic problems, Kim did not pull back on this experiment because it expanded his control at the local level, eliminating any bureaucracy between him and the people.

In addition to providing guidance at the local level, the regime once again reinforced its control and monitoring of the *songbun* system. The Citizen Registration Bureau and the Resident Registration Bureau, which had been created in 1964 as part of the implementation of the *songbun* system, were expanded and folded into a new organization called the Resident Registration Bureau.²¹⁸

In 1976, Choe Won-ik assumed the portfolio of Minister of Public Security, replacing Ri Chin-su, who became Procurator General of the Central Procurator's Office.²¹⁹ Choe's background is unclear up to 1969, when he became the director of the General Political Department of the Ministry of National Defense. This transfer could have been tied to Kim Jong-il's evolving relationship with O Chin-u, the Minister of National Defense, who was a key supporter of the dynastic succession.

By the late 1970s, Kim Jong-il had used the monolithic guidance system to transform North Korea into a modern totalitarian state. An intensive regimen of inspec-

Kim Il-sung, "Once the people's thinking has been remolded so that they can recall their revolutionary enthusiasm, all problems of revolution and construction can be solved successfully."

218 It is impossible for North Korean citizens to move their residence at will. If a person wishes to move, he must obtain a residence certificate, an exit permit, and an employment certificate.

219 At the Sixth Supreme People's Assembly in December 1977, Choe Won-ik was formally announced as Minister of Public Security. *Nodong Sinmun*, 18 December 1977.

tions as well as an expanding police apparatus supported this system, through which Kim created his own ties to the internal security apparatus.

Kim Jong-il as Heir Apparent (1980–1994)

Kim Jong-il's first public appearance came at the Sixth Party Congress in October 1980. At the Congress, Kim was elected a standing member of the Politburo, a secretary of the Secretariat, and a member of the Central Military Committee. Except for Kim Il-sung, Kim Jong-il was the only other member of all three of these leading party bodies. The Congress also unveiled the plans for a dynastic succession with Kim Jong-il formally designated as the heir.

Kim Jong-il's move into the upper echelons of the KWP was accompanied by the promotion of individuals in the security apparatus to key posts in the party. Chon Mun-sop and Paek Hak-nim, both vice ministers of Public Security, were appointed to the Politburo. Both members of the partisan faction and closer to Kim Il-sung than his son, their promotion most likely signaled an effort to guard against any backlash from Kim Jong-il's selection as heir apparent. At the Congress, the Procurator General and former Minister of Public Security Ri Chin-su warned against opposing the tapped next leader—a point later reiterated in *Nodong Sinmun*.²²⁰

After the Sixth Party Congress, North Korea publicly accelerated the cult of Kim Jong-il. His biographical writing was first published in 1982. On February 15 of

²²⁰ Jae Kyu Park, B.C. Koh, and Tae-hwan Kwak, eds., *The Foreign Relations of North Korea: New Perspectives* (Seoul, Korea: Kyungnam University Press, 1987). In his speech to the Congress, Ri acknowledged that there had been internal party opposition to Kim Jong-il's rise and that a very small number of antagonistic elements still remained. *Far Eastern Economic Review*, 24 April 1981.

the same year, a day before Kim Jong-il's birthday, the North Korean government awarded him with the title of Hero of the Democratic People's Republic of Korea, making reference for the first time to Kim's birth on the legendary Mt. Paekdu.²²¹

The move to enhance his cult of personality was accompanied by Kim Jong-il's increasing control over the security apparatus. At the 1st session of the 7th SPA in April 1982, the Public Security Department was transferred from the Administration Council to the KWP. Kim also brought the SPSD under his direct control within the KWP Secretariat, changing its name to the State Security Department (*Gukga An-jeon Bo-wi-bu, SSD*). Kim Pyong-ha, who had contributed greatly to consolidating the Kim Il-sung system and completing the hereditary system of power succession, was purged by Kim Jong-il for supposedly alienating the party and masses by executing innocent people.²²²

221 *Nodong Sinmun*, 15 February 1982.

222 From 1973, the SPSD arrested and executed countless numbers of "reactionaries," instilling fear throughout the country. But by 1981, Kim Pyong-ha was called a "factionalist" and "counter-revolutionary element" for not uncovering several anti-Kim Jong-il movements. Realizing that he was no longer necessary, Kim Pyong-ha ended his life by shooting himself in his office.

Kim was replaced by Ri Chin-su, the former Minister of Public Security. Kim Jong-il also ousted all the SSD vice directors and directors and appointed many of his devoted followers who had been working under him in the KWP's Organization and Guidance Department. He also curtailed the SSD's powers and instructed it to concentrate only on rounding up spies without becoming involved in economic and other party work. In the following months, the SSD was subjected to an extensive purge and thousands of officers who were deemed to be closely related to Kim Pyong-ha were sent to labor camps with their families.²²³

North Korean Prisons in the Early 1980s

At least 105,000 residents in North Korea were being detained at various concentration camps for ideological charges. In addition to 25 prisons in which ordinary criminals were kept, there were allegedly eight prisons exclusively for political prisoners. This was confirmed through a defector in April 1982. Among those being kept in these concentration camps were such high-ranking personalities as Pak Kum-chol (75), secretary to the KWP Secretariat; Kim Kwang-hyop (67), former National Defense Minister; Ho Pong-hak (76), former four-star general in the KPA; and Yu Chang-sik (59), former vice chairman of the South-North Coordination Committee. All of them were reportedly charged with opposing the succession plan.

Source: 2009 White Paper on Human Rights in North Korea (Seoul: Korea Institute for National Unification, July 2009).

After Ri Chin-su was appointed the SSD director, Kim Jong-il took control of the agency, frequently receiving briefs on its work status and issuing instructions. Whenever an important or urgent issue arose, the SSD director visited Kim Jong-il at his discretion and always accompanied Kim when he went on on-the-spot guidance to

²²³ Andrei Lankov, "A Spyhole into North Korea," *Korea Times*, 17 September 2004.

Kim Pyong-ha's Fate (paraphrased from *Pyongyang Dreams of Exile*)

“Kim Pyong-ha was brought down by the ‘15-persons incident.’ By 1979, Kim Pyong-ha’s actions had become troublesome for Kim Jong-il. 15 veteran partisans within the SPSD, who had fought alongside Kim Il-sung during the Korean War, sent a joint letter to Kim Il-sung listing unacceptable things Kim Pyong-ha had done. This letter was a problem for Kim Jong-il, who at the time was involved in a power struggle over succession and preparations for the Sixth Party Congress.

When he learned of the document, Kim Jong-il summoned Kim Pyong-ha and tossed the letter to him without even reading through it. He asked, ‘What is this?’ and told him, “Be careful.” Reading the letter, Kim Pyong-ha went pale, because if that letter had gotten to the hot-tempered Kim Il-sung, he knows he would have been executed immediately.

Kim Pyong-ha immediately arrested the 15 persons and imprisoned them in the No. 14 Political Criminal Management Center, in Kaechon County, South Pyongan Province. The No. 14 Management Center is said to be the harshest of all detention centers. At first Kim Pyong-ha meant to accuse them of crimes against the revolution and have them shot. However, it was not easy to try hanging false charges on them, because they had done meritorious service in the Korean War. The investigation took several months.

In the meantime, one of the 15 men was able to escape and went to Mt. Chamo Fortress, Pyongsong, where a Kim Il-sung villa was located. There, he contacted his brother, who was a Political Committee member. He wrote down the full story of the events in detail, and his brother was able to have the document delivered directly to Kim Il-sung in the presidential palace through secret channels.

After the Sixth Party Congress was finished (October 1980), the State Political Security Department received a special instruction. It said there was to be a special event tomorrow, so they should call in all members (staff) who were away. Knowing there was some event, the full staff of the SPSD was on standby.

The next day, a brigade of Kim Jong-il’s personal guards surrounded the six-story SPSD building in Misan-dong, Taesong District. The special instruction had been a ruse. After all the SPSD personnel had been forced to surrender their weapons, ideological examinations began. The one in charge of Kim Pyong-ha’s ideological examination was Kim Chi-ku, the first deputy director of the KWP Organization Guidance Department. Realizing his fate, Kim Pyong-ha took his own life after only three days of ideological examination. That was in March 1981.”

*Source: Kang Myong-to, *Pyongyang Dreams of Exile* (Seoul: JoongAng Ilbo, 1995).*

provinces. Therefore, it was not surprising that when Ri Chin-su died,²²⁴ Kim did not replace him, preferring instead to take direct control over the SSD through its first deputy director, Kim Yong-yong.²²⁵

“My middle school classmates knew that one of our classmates’ father was taken by the *bo-wi-bu* [SSD]. The father, who was a foreman at the time, had disappeared soon after saying a ‘few grumbling words’ about the regime while drinking with his co-workers. After the man’s wife was called in for questioning multiple times, they were divorced from one another. Since that time, neither the wife nor my classmates have heard a word about him.”²²⁶

In 1985, Kim Jong-il restructured the command and control of the security apparatus. He engineered the demotion of Chon Mun-sop and Paek Hak-nim from the Politburo, although Paek was appointed the Minister of Public Security.²²⁷ Kye Ung-tae, a deputy premier in the Administration Council, was brought into the KWP Secretariat and given the portfolio for public security.²²⁸ Jang Song-u, an elder

224 Ri died of chestnut tree gas poisoning while sleeping in the bedroom of a county security department during a visit to Hwanghae Province in August 1987 to observe the provincial SSD.

225 Born in Pyongyang in 1942 Kim Yong-yong enjoyed a special confidence from Kim Jong-il as a former fellow student at Kim Il-sung University. He was demoted for a brief time in 1989, however, for failing to promptly brief Kim Jong-il on an important incident that took place during the Pyongyang Festival in the immediate wake of the 13th World Festival of Youth and Students. He was sent to North Hamgyong Province as the provincial security director. Kim Jong-il summoned him back in 1991 and re-appointed him to his original position as SSD first deputy director.

226 Author’s discussions in Seoul, April 2009.

227 In 1986, Ri Chol-pong was appointed director of the Ministry of Public Security’s Political Department. Ri, a graduate of Mangyongdae Revolutionary School and a former major general in the KPA, was close to Kim and may have served as a check on Paek Hak-nim. Ri went on to serve in a number of cabinet positions before becoming Chief Secretary, Kangwon Provincial Party Committee in 2006. He died in December 2009.

228 Kye Ung-tae was elevated to the Politburo in 1988.

brother of Jang Song-taek, Kim Jong-il's brother-in-law and an increasingly powerful figure within the KWP Organization Guidance Department, was appointed first vice minister of public security.²²⁹ During this period, Ri Nam-son took over the Ministry of People's Armed Forces Security Bureau from O Yong-pang. These moves suggested that the opposition to Kim's role as heir had finally been stamped out. In May 1986, at the Kim Il-sung Party School's fortieth anniversary, Kim Il-sung declared that the political succession had been satisfactorily resolved.²³⁰ An indication of the return to standard operating practices within the regime was the return of the Public Security Department to the Administration Council at the Eighth SPA in December 1986.

In December 1991, Kim Jong-il took over the position of Supreme Commander of the KPA. After a revision of the Constitution the next year to separate this post from the presidency and attach it to the chairman of the National Defense Commission, Kim also assumed this latter post in 1993. The succession process that began in 1974 was complete. For all intents and purposes, Kim Jong-il now controlled all the levers of power.

At the Third Session of the Ninth SPA held in April 1992, command and control of the security apparatus was altered. The SSD was subordinated to the NDC. The Public Security Department remained under the Administration Council, which was given the new mandate for "maintaining social order, protecting the belongings

229 Jang Song-u was appointed first vice minister in 1989. According to some defector accounts, Paek Hak-nim had begun to show signs of senility in the late 1980s. Jang Song-u, these accounts contend, actually ran the day-to-day operations of the ministry. In 1991, Jang became the director of the ministry's political department, a position he held until 1995 when he became commander of the Third Corps.

230 *Nodong Sinmun*, 1 June 1986. Beginning in the mid-1980s, Kim Il-sung became semi-retired. He retained the role of guardian of his successor in domestic politics and dealt primarily with diplomatic affairs.

and interest of the state and cooperating organizations, and securing people's rights." While security work was highlighted as a function of the cabinet, the NDC also allegedly exerted a great deal of control over the Public Security Department.²³¹

It is interesting to note that the SPA meeting was held in the wake of a rumored failed *coup d'état* in Pyongyang. According to one senior North Korean defector, in March, the SSD uncovered a plot by a group of disaffected North Korean military officers to carry out a coup on April 25 during the parade in commemoration of the 60th anniversary of the founding of the KPA.²³² The conspiracy was allegedly headed by Deputy Chief of General Staff An Chong-ho and included several officers who had been trained at the Soviet Union's Frunze Military Academy.²³³

The SSD sent a report up to Kim Jong-il via secure channels. Kim Jong-il did not leave the handling of this matter to the SSD, but entrusted it to the Ministry of

231 Dr So' Chae-chin and Dr Kim Kap-sik, *A Study of the North Korean Ministry of People's Security* (Seoul: Korean Institute for National Unification, 2008).

232 According to Kang Myong-to, who is former North Korean Premier Kang Song-san's son-in-law, the SSD was tipped off by a former Russian intelligence operative. See Kang Myong-to, *Pyongyang Dreams of Exile* (Seoul: JoongAng Ilbo, 1995).

233 Leading members of the conspiracy were classmates of Kim Jong-il within one to three years, and they allegedly believed that the "incapable" and "bad-natured" Dear Leader was being installed into power on the shoulders of his father. According to Choe Chul-hwal, a former colonel in the KPA who defected in 1995, Kim Jong-il in the aftermath of the attempted coup issued instructions for a massive purge of the officer corps. Between October 1992 and June 1994, North Korea arrested and executed nearly 300 (of 370) high-ranking military officers, except Air Force pilots, who had studied in the Soviet Union in the 1980s. North Korean intelligence officials argued that during the 1980s, the Soviet Union not only assisted North Korea in modernizing its military, but covertly helped to form a pro-Soviet organization within the KPA. Some of the more notable officers purged included: Col. Gen. Hong Kye-song, deputy chief of the General Staff; Maj. Gen. Kang Un-yong, head of the Third Department of the MPAF's Operations Bureau; and Maj. Gen. Kim Hak-san, the director of the MPAF's Foreign Affairs Bureau. VMAR Cho Myong-nok and Won Ung-hui allegedly convinced Kim Jong-il to spare the Air Force. "300 High Ranking Officers Executed," *JoongAng Ilbo*, 21 March 1996.

People's Armed Forces (MPAF) Security Bureau, headed by Won Ung-hui.²³⁴ Kim Jong-il was likely concerned that entrusting an MPAF investigation to the SSD, when the two were mutually antagonistic, would lead to a turf war within the security apparatus, something he wanted to avoid given the fault lines that still existed within the regime following the announcement of his succession.

Fate of the 1992 Conspirators (from *Pyongyang Dreams of Exile*)

“On the afternoon of the next day, An Chong-ho came to work in the office of the vice chief of the General Staff on the sixth floor of the MPAF building in Sosandong, and two security personnel kicked the door open and hauled him off. Subsequently, the officers of the Frunze school who had acted together in the rebellion were arrested and dragged away somewhere, one or two at a time. A month after that, the sound of automatic-rifle fire rang out every night for several days, like the popping of roasting beans, at a firing range used by the MPAF. Kim Jong-il was afraid that the fact of plans to undertake a coup d'état would be revealed if he sent them to trial, so he executed them in secret. In addition, their families were dragged away by security personnel who rushed upon them one night, and they were sent to the No. 16 Political Criminal Detention Center, which is a district for special control in North Hamgyong Province.”

*Source: Kang Myong-to, *Pyongyang Dreams of Exile* (Seoul: JoongAng Ilbo, 1995).*

This was also a period of growing concern about South Korean attempts to penetrate the North Korean regime. Since the mid-1980s, the SSD had focused much of its energy on exposing ethnic Koreans in China and the Soviet Union (later Russia) working as spies for the South Korean intelligence agency.²³⁵ Together with the

234 Won Ung-hui had taken over the command of the Ministry of People's Armed Forces Security Bureau from Ri Nam-son in 1992.

235 The increasing number of visits by ethnic Korean residents in China to their North Korean relatives, which began to surge from the early 1980s, together with a wave of reform and open-

MPAF's Security Bureau, the SSD conducted surveillance of students studying at universities and the military academies. Once evidence was secured, they were arrested and executed or moved to the management offices for political prisoners. In the aftermath of the 1992 coup attempt, Kim Jong-il reportedly issued instructions that those who had studied in the Soviet Union were to be uniformly fired from important positions and stripped of their power.²³⁶

Intrigue Following Kim Il-sung's Death (1994–1998)

On July 8, 1994, the North Korean media announced that the Great Leader Kim Il-sung had died suddenly of heart failure. This news sent a seismic shock throughout the population, including the North Korean leadership, which was caught off guard. The chaos unleashed within the regime was reflected in the fact that the state funeral was not held until 11 days after Kim's death.²³⁷ In adherence to the Confucian tradition of paying tribute, Kim Jong-il observed a three year mourning period, waiting until the 10th SPA to announce his new regime. In the meantime, Kim faced several challenges to his leadership, which had a dramatic impact on the configuration of the internal security apparatus.

ing in China, created a favorable environment for the South Korean intelligence agency to gather intelligence on the North. When South Korea and China established official relations in 1992, Kim Jong-il took measures to deal with this unfolding security threat on North Korea's border. In 1993, the SSD underwent a series of organizational changes, including the creation of the Border Blockade Department and Strategy Department under the Overseas Counterintelligence Bureau. The SSD also expanded and strengthened its overseas espionage organizations so as to constantly observe the South Korean intelligence agency's direction and movements related to northward operations.

236 Yun Tae-il, *The Inside Story of the State Security Department*, op. cit.

237 For a detailed examination of how the regime handled Kim Il-sung's death, see Ken E. Gause, *North Korea Under Kim Jong-il: Power, Politics, and Prospects for Change* (Santa Barbara, CA: Praeger, 2011).

By the mid-1990s, a realignment of power and influence was unfolding within the North Korean security apparatus between the SSD and the MPAF's Security Bureau. The Security Bureau had proven its efficiency and strong loyalty during the 1992 coup investigation. In the aftermath of Kim Il-sung's death in 1994, Kim Jong-il on at least two occasions found the SSD wanting and turned again to the Security Bureau to take the lead in high-profile investigations.²³⁸ As a consequence, Lt. Gen. Won Ung-hui, the commander of the Security Bureau, was promoted to colonel general and the Security Bureau was elevated to the Security Command, thus increasing its importance within the military hierarchy on par with that of the General Staff and General Political Bureau.²³⁹

Kim also gave the Security Command a broader portfolio to operate outside military boundaries and involve itself in party affairs.²⁴⁰ The SSD's influence, as a consequence, suffered. SSD deputy director Kim Yong-yong was branded an "anti-party and anti-revolutionary sectarian." He committed suicide in 1998 and his family was reportedly sent to a political prison camp.²⁴¹ The SSD's Unit 5454 (Border Security Forces, Railway and Coast Guards) was transferred to the MPAF.²⁴²

238 In the early 1990s, Kim Jong-il bolstered the resources of the Public Security Department and the SSD to meet growing "non-socialist" behavior. But, both organizations suffered from morale problems and growing corruption and often became overwhelmed by growing local crimes.

239 Won Ung-hui's relationship with Kim Jong-il allowed the Security Command to operate autonomously from the MPAF.

240 According to one North Korean defector, in 1997, the Security Command was given latitude to independently investigate KWP officials. This marked a departure from previous procedures when the Security Command had to join with the SSD when conducting such investigations. This new latitude allowed Kim Jong-il greater oversight of SSD operations and provided a check against other powerful figures within the North Korean security apparatus, such as his brother-in-law, Jang Song-taek.

241 Kang Myong-to, *Pyongyang Dreams of Exile*, op. cit.

242 This move reportedly enhanced the competition between the SSD and the Security Command. By removing the border guard function from the SSD, it lost its complete control over the

As for the Public Security Department, it was also involved in the political intrigues of the late 1990s. As the severe food crisis swept across North Korea, giving rise to starvation, roaming beggars, and escapees to China, the regime's registration files on the public became outdated.²⁴³ It was difficult for the leadership in Pyongyang to determine how many people had died and gone missing. Kim Jong-il, therefore, called upon the Public Security Department to conduct a nationwide resident re-registration.²⁴⁴ In the process, it came to light that some cadres and residents had hidden problems in their backgrounds. The investigation intensified under Jang Song-taek's guidance. He was assisted by Chae Mun-tok, the director of the Public Security Department's Political Bureau.²⁴⁵ As a result of this investigation, many senior members of the party were accused of being spies for South Korea or the

Chinese-North Korean border, a source of much revenue for the secret police.

243 Each provincial Public Security Department (Ministry of People's Security today) is tasked with registering and tracking individuals within its territory. The national level ministry's department for resident registration is responsible for preserving and managing past records of the entire North Korean population and investigating and recording any changes. The scope of investigations into residents' past includes great grandparents and grandparents, parents, the resident himself, spouse, uncles, cousins, fifth, sixth, seventh, and eighth cousins, maternal grandparents, maternal uncles, and maternal cousins. They cover all the people who are deemed capable of being politically and economically influenced by the residents under inspection, and the investigations have to disclose (explain) every detail of their past without leaving any blanks. Kang Myong-to, *Pyongyang Dreams of Exile*, op. cit.

244 Other defectors note that the focus of this purge was not only senior party members suspected of espionage and financial malfeasance, but also officials returning to Pyongyang after having served in official assignments abroad. Diplomats and members of the KWP's International Department were allegedly executed as part of this purge.

245 According to defector accounts, in the late 1990s or early 2000s, Chae was purged. A close confidant of Jang Song-taek and Kim Kyong-hui, Chae was eager to show his loyalty and in doing so fabricated a story and reported to Kim Jong-il that during the Korean War, a group had been formed to assassinate Kim Il-sung. Kim Jong-il ordered an investigation and purge of those involved in the plot. Later when the fabrication was discovered, Chae himself was killed on Kim's orders and the senior police officials (both central and local officials) who had been taking orders from Chae were summarily arrested and sent to Yodok political prison camp. See "Raw Testimony From Escapees Who Returned From 'Hell'—Former High-Ranking Government and Police Officials Thrown Into Political Prison Camps Without Mercy," *Yomiuri Weekly*, 04 May 2008.

1995 6th Corps Incident

In June 1995, an SSD agent in Nanam District of North Hamgyong Province acquired intelligence that a possible *coup d'état* was being planned within the 6th Corps. The provincial SSD director ordered an investigation. The investigation, however, was apparently shelved shortly thereafter for lack of evidence. The original source supposedly then went to the MPAF Security Bureau in Pyongyang with the information. The Security Bureau's investigation apparently came to a different conclusion, finding evidence of a plot involving elements within the 6th Corps' Political Department and artillery units, both of which were involved in smuggling steel to Japan. As a result of the Security Bureau's investigation, several 6th Corps officers were executed, as were powerful provincial party and SSD officials. The 6th Corps was dismantled.

KSYL Incident

In May 1997, the Mangyongdae District (Pyongyang) SSD acquired information alleging that several senior functionaries in the Kim Il-sung Socialist Youth League (KSYL) Central Committee, including First Secretary Choe Yong-hae, had been bribed and entertained by South Korean youth representatives when they met at a conference in Beijing. The district SSD reported the incident to SSD First Vice Director Kim Yong-yong. Upon investigation, Kim Yong-yong allegedly discovered that Kim Jong-il's brother-in-law and powerful First Deputy Director of the KWP's Organization Guidance Department, Jang Song-taek, was close to some of the suspects. As a consequence, Kim Yong-yong decided not to report the incident to Kim Jong-il directly, but to refer the matter to KWP Secretary for Public Security Kye Ung-tae, who apparently also chose not to report it to Kim Jong-il. Again, the MPAF Security Command found out about the SSD's reluctance to pursue the investigation and launched its own inquiries. Won Ung-hui apparently reported the details to Kim Jong-il, who in turn entrusted the investigation to the Security Command. As a result of the investigation, the KSYL and SSD were purged and Jang Song-taek and Kye Ung-tae fell out of favor. For a period, Chang asked for punishment and was forgiven by Kim Jong-il. The Security Command's authority was expanded, including oversight of border guard units to root out bribery and corruption.

Source: Kang Myong-to, Pyongyang Dreams of Exile, op. cit.

United States. Even Kim Jong-il's close aides could not escape the drag net, including: Mun Song-sol, chief secretary of the KWP headquarters; So Kwan-hi, KWP Secretary of Agriculture; and So Yun-sok, chief secretary of the South Pyongan Provincial Party Committee.

Sim-hwa-jo Sa-eop (“Intensification Operation”) Incident

In 1997, the Public Security Department began a campaign to investigate the background of senior figures in the party, government, and military, looking for gaps in their cadre registration histories. The so-called “Intensification Operation,” which was conducted at the central and provincial levels, was ostensibly aimed at ferreting out those responsible for sabotaging the country’s food supply in the wake of the famine. It eventually led to the rounding up of more than 30,000 officials and their families, many of whom were incarcerated or executed. In 2001, the campaign was brought to a close as it was ascertained that many innocent people were sacrificed. Chae Mun-tok, the chief of the political bureau of the Ministry of People’s Security (former Public Security Department) and Hwang Chin-taek, the chief of staff, were held responsible. Chae was executed by firing squad and the ministry was purged of many who were directly involved in the campaign.

Purge of So Kwan-hi

According to some defector reporting, in the early 1990s, the Yongsong District (Pyongyang) Public Security Department as part of its examination of its resident registration files discovered that So Kwan-hi's whereabouts for 20 days during 1950 were unexplained. Subsequent investigations at the provincial level suggested the possibility that So might have had contact with agents from the South. When these findings were passed to headquarters in Pyongyang, allegedly senior members of the Public Security Department tried to stop the investigation because of So's close ties to Kim Jong-il. These efforts failed and the case came to the party's attention in 1997. So Kwan-hi and several others implicated in the case were allegedly publicly executed in front of hundreds of Central Committee senior functionaries. The headquarters of the Public Security Department was purged, although Paek Hak-nim was spared.

According to some sources, So Kwan-hi was executed not for ties with agents during the Korean War, but for a failed agriculture policy. The so-called Sim-hwa-jo Sa-eop incident was fabricated to placate the growing public aggravation with food shortages. It also gave the regime an excuse to divert the public's complaints toward outside hostile forces.

Source: Kang Myong-to, Pyongyang Dreams of Exile, op. cit.

“In 1998, in the area of Songchon River in Hamheung, a grandmother survived alone after her son died from starvation. She lamented and wept loudly, letting slip the comment, ‘This damn world!’ The next day, she disappeared without a trace.”

P370, [ID032], 2008 Whitepaper on Human Rights in North Korea (Seoul: Korean Bar Association, 2008)

During this period, the Public Security Department was also engaged in several turf battles with the SSD.²⁴⁶ These struggles often resulted from the blurred lines of authority between the two security agencies. While coordination often occurred at the investigation level, the SSD could only handle those crimes committed against the state and was not supposed to interfere in economic or social cases. These lines, however, were often crossed. In addition, the SSD, according to some sources, planted agents in the Public Security Department to check for anti-government activity.

Kim Jong-il Regime

In the 1990s, the security apparatus became more complex as Kim began to elevate the role of the National Defense Commission (NDC). Kim Jong-il took the position of Supreme Commander in 1992 and, after his father's death in 1994, he was able to fortify his power over the military. The State Security Department was placed under the NDC, but reported directly to Kim. At the same time, the Military Security Command, which reports to the Ministry of People's Armed Forces, began to accumulate power as Kim used it to quash potential opposition within the armed forces and in the provinces.

The Party's control over the security agencies changed after 2006. Within the KWP, the Organization Guidance Department (OGD) still played a dominant role, but while the OGD ensured loyalty within the security organs through their political

²⁴⁶ In the mid-1990s, Kim Jong-il criticized the MPS for failing to accomplish its mission of maintaining social order. Its failure opened the door for the SSD and MSC to enhance their role in law enforcement. In an attempt to rebuild its image, the MPS embarked on a national campaign to root out spies and "impure elements" by checking the backgrounds of cadres—the so-called *Sim-hwa-jo* incident.

offices, it was the Administrative Department, under Jang Song-taek, that maintained the party's day-to-day control over the SSD and the Ministry of People's Security.²⁴⁷

The changes made to the National Defense Commission at the 12th Supreme People's Assembly in April 2009 held important implications for the evolving role of the internal security apparatus. The NDC membership was increased from eight to twelve, with three of the new members (Jang Song-taek, Chu Sang-song, and U Tong-chuk) coming from the internal security apparatus.²⁴⁸ For the first time, the membership of this increasingly important body was not only affiliated with the military; it embraced all aspects of North Korea's domestic security apparatus as well.

This new configuration was part of a strategy to consolidate the channels through which Kim Jong-il ruled the regime. In the past, Kim had relied on informal ties into a variety of organizations that often trumped formal chains of command. This leadership style was cumbersome and relied on frequent interactions with a number of subordinates. This forced the agencies to rely on Kim Jong-il for every important decision. When his health declined, however, Kim's ability to continue with this method of rule became untenable.²⁴⁹ The enhancement of the NDC's role institutionalized dedicated channels for the flow of information and guidance. Reporting lines related to internal security were largely consolidated under Jang Song-taek.²⁵⁰

247 Author's discussions in Seoul, April 2009.

248 The addition of five new members represents the largest increase in formal membership in the Kim Jong-il era (since 1994) and expands the organization to its largest reported size since its establishment in 1972.

249 "A Strategic Move Toward a Collective Leadership System for Post Kim Jong-Il Era," *Facta*, 1 May 2009. Author's discussions with North Korean defectors and South Korean, Japanese, and Chinese Pyongyang watchers, March-April 2009.

250 According to one South Korean source, one of Jang Song-taek's deputies has oversight responsibility for the Ministry of People's Security.

Both Chu Sang-song (Minister of People's Security) and U Tong-chuk (Deputy Director of the State Security Department) reported directly to him in his capacity as Director of the KWP Administration Department, yet they were given their own position on the NDC, strengthening Jang's power.²⁵¹ Kim Won-hong, the head of the Military Security Command, reported to the NDC via the Ministry of People's Armed Forces.²⁵²

The evolution of the command and control of the security forces was intimately tied to Kim Jong-il's attempts to consolidate his power and deal with the challenges facing the regime. Throughout much of the 1990s, Kim had to deal with an economy that was falling apart. A series of great floods had propelled the economy into free fall. According to the United Nations, an estimated 5.2 million people were affected in 145 counties (out of 200) in eight (out of nine) provinces. Hundreds of thousands starved in what Kim referred to as North Korea's "Arduous March." The government was revealed to be dysfunctional in addressing the economic calamity. Private markets began to crop up to fill the void and a vibrant gray economy emerged. Many people crossed the border into China.²⁵³

251 According to North Korean defector sources, the SSD director's responsibilities in recent years have been assumed by one of the KWP Administration Department's deputy directors. As a counter-balance, the deputy director of the SSD (U Tong-chuk) reports up through the KWP Organization Guidance Department. Because of the relationship between Chang and U, it is not clear whether this balance between the Administration and Organization Guidance departments remains in place. Author's discussions in South Korea, April 2009.

252 According to some sources, the MSC now directly reports to the NDC. Author's discussion with a senior North Korean defector, May 2009.

253 In the mid-1990s, Yanggang-do was the area most frequently used by illegal border crossers. By the late 1990s, it shifted to Hoeryong in Hamgyong Province. By 1999, Yunson became the area of choice for border crossers. All three of these areas had Chinese cities nearby where the border crossers could find refuge. In the late 1990s and early 2000s, the bribes for border crossings allegedly increased from 100 to 500 North Korean won. Border guards during this period often let illegal border crossers pass if they were able to pay the bribe. Those involved in human trafficking, however, were subject to incarceration in Ministry of People's Security detention facility or execution, depend-

The deteriorating economy had an impact on the regime's ability to control the population. Since its inception, the North Korean regime controlled the population by restricting movement within the country. In the 1990s, these restrictions were considerably relaxed, since after the collapse of the North Korean economy an increasing number of people had to resort to small-scale barter trade as the main mode of survival, and the government had to lift travel bans, a major obstacle to such trade.²⁵⁴

Famine and the economic crisis struck a crushing blow against the entire system of administrative and police control. Although the old instructions and restrictions were not formally revoked, in practice they ceased to be implemented. Officials—mainly at the grassroots level—began taking bribes and ignoring their duties, knowing that the state was no longer capable of adequately rewarding their official zeal.²⁵⁵ As a result many bans that continued to exist on paper became a fiction in practice. In particular, movement inside the country became almost free—a travel permit could be obtained by giving a bribe of a few dollars (although on the whole the authorities managed to maintain control of entry into Pyongyang). Numerous bans aimed at restricting the private sector also ceased to operate.

While this period of relaxation went against the instincts of the North Korean regime,

ing on the seriousness of the crime.

254 During this period, the regime issued a directive on how to deal with those who attempted to cross the border into China. All escapees were to be detained at the regional SSD office for interrogation. If the crime was deemed a misdemeanor, the person would be sent to a labor training camp for one to two months. For more serious crimes, such as interacting with South Koreans while abroad, the person would be transferred to the provincial SSD for trial. This meant either detention in a political prison camp or execution.

255 An example of how lax the system became was that in the past, anyone reported to the SSD for expressing dissatisfaction with the regime was severely punished. By 1996, the rules had changed. Reports were no longer sufficient grounds for punishment. Now, an SSD agent had to actually hear the criticism. Discussion with North Korean defector in April 2009.

it enabled the country to survive in spite of the state's abrogation of its most fundamental responsibilities of governance. By 1998, Kim Jong-il was confident enough that the regime could survive that he convened the 10th SPA to place his stamp on the regime. The year before, he had assumed the post of KWP General Secretary, violating party by-laws by foregoing the formal Central Committee selection process. At the SPA meeting in April 1998, Kim Jong-il was re-elected as chairman of the NDC, which was elevated in status by the new constitution. By strengthening this institution, Kim demonstrated how he would rule the country in the future. The NDC was his organizational base to implement his military-first politics. The new constitution also transformed the Administration Council into the Cabinet and gave it greater autonomy by eliminating the presidency and the Central People's Committee. As part of this reform, the Public Security Department became the Ministry of Public Security, a name that lasted until the third meeting of the SPA in April 2000, when it was renamed the Ministry of People's Security.

Hwanghae Steel Works Incident

In 1998, robbery, homicides, and rapes were rampant in Songnim City, Hwanghae Province. During this period, machinery components were taken from the Hwanghae Steel Works for sale by workers for food. At first the Public Security Ministry tried to tackle the situation. However, as the problem grew serious, the Military Security Command surrounded Songnim City, even mobilizing tanks, and launched an all-out investigation. The results showed that the security department chief and some other cadres in Songnim led corrupt lives in collusion with five gang organizations.

When the Security Command plastered on walls a public warning that "all of those involved would be executed unless the machinery components were returned within 24 hours," they collected most of the components that had been taken. In connection with the incident, 19 persons, including the party secretary and manager of the Hwanghae Steel Works and some gang leaders, were executed by firing squad in public.

Source: "Security Command Engineers Purges in DPRK—Hwang Chang-yop," JoongAng Ilbo, 11 February 1999.

The relaxation of state control continued for the next few years. In 2001-2002, cell phones began to appear and the number of subscribers to the North Korean cell phone network reached 20,000. The regime even began to make noises about officially embracing the unofficial reforms (the so-called “July 1st measures”). Foreign commentators began to speculate that North Korea had finally embarked on the path of economic reform similar to those that had taken place in China.

In 2004, this period of relaxation came to an end as North Korean authorities attempted to turn the clock back to the days of Kim Il-sung. The regime began to pursue a new policy agenda aimed at revoking all the changes that had taken place over the previous decade. Cell phone ownership by private individuals was banned.²⁵⁶ In 2005, the government banned the private trading of grain and revived the rationing system.²⁵⁷ It also placed severe regulations and oversight on the markets. In 2007, the KWP Central Committee issued a document on the “problem of the markets,” calling them “breeding grounds for speculators.”²⁵⁸ While bans against the selling and viewing of contraband movies (especially from South Korea) never ceased, a campaign began in 2005 to devote more attention to this issue.²⁵⁹ Enhanced baggage inspections on trains and buses are an example of this campaign. Controls were also strengthened on the border with China, which has led to a dramatic reduction in the

256 “Ban on Cell Phones in the North Confirmed,” *Hankook Ilbo*, 4 June 2004.

257 By May 2008, South Korea’s National Intelligence Service estimated that about 60 percent of the North Korean population was receiving full (540 grams per day per adult) or almost full rations. The less privileged segments of the population receive between 300 and 400 grams and still need to resort to the open market to make up the difference. See “They Receive Only Half the Minimum Food Necessary,” *Kyonghyang Sinmun*, 24 May 2008.

258 *Rimjingang*, No. 2 (2008).

259 “North Koreans Continue to Talk about ‘Deliverance from Capitalism,’” *Daily NK*, as cited in Andrei Lankov, “North Korea: Attempt at Counter-reforms,” *Sluchaynyye Zametki*, 16 March 2009.

number of North Koreans crossing the border.²⁶⁰ According to 2008 reports, there was an increase of periodic checks by “groups for combating anti-socialist phenomena” on police and security service personnel in the border zones in an effort to combat corruption.²⁶¹ Several local officials, convicted of corruption, were executed.

Restrictions on Classified Documents

The types of documents that can be classified as secret documents have increased in number significantly compared to before. According to one source, “Documents that had been previously preserved in the party secretary’s or the manager’s office in each factory have been handed over to the ‘Proceedings Department’ (the department that is in charge of keeping important documents) and have been directly inspected and checked by officers from the Ministry of People’s Security. In order for primary secretaries of the party to peruse important documents, they must receive prior approval from the Ministry of People’s Security officers and security managers in charge of the factory dispatched from the State Security Department.”

He added: “In order to look at average documents by the level of classification, people have to receive approval from the primary secretaries of the party and for important documents permission from the SSD security managers and Ministry of People’s Security officers must be granted.”

North Korea’s cadres have justified these measures, saying: “This is due to the increase in the number of spies who have been leaking national secrets,” but it was since the end of October 2008, when rumors of Kim Jong-il’s illness began to increase significantly, that the heightened regulation of documents has been observed.

Source: “‘Source’ Reports North Korea Tightens Controls Over Documents,” The Daily NK, 16 December 2008.

260 “Ten Years of Defections from the North: The Number is Falling, the Quantity of Representatives from Different Social Groups is Increasing,” *Daily NK*, 14 May 2007. According to the *2008 White Paper on Human Rights in North Korea*, Pyongyang relaxed the level of punishment on escapees when it revised its Constitution in 1998 and Penal Code in 2004. As the number of border crossing people increased drastically after 1998 and as law and order broke down under the economic hardship, the authorities were forced to relax the punishment levels for the “economic defectors.” No one appears to have been sent to a political prison camp for a defection crime since 2000. Most of the returning escapees had to undergo 1-6 months of “labor-training” at labor training camps. But since 2004, the level has been raised again, and in 2006 and 2007 the escapees’ family members remaining in North Korea have been forcibly relocated to remote areas.

261 *North Korea Today*, 29 October 2008.

This shift toward a harder line policy overlapped with a significant realignment of the internal security apparatus. In July 2004, Choe Yong-su,²⁶² who had been appointed Minister of People's Security only the year before, was replaced by Gen. Chu Sang-song. Some Pyongyang watchers speculated that Choe's removal was tied to the purge of the Jang Song-taek faction.²⁶³ While the reason is not clear, his removal did take place in the midst of criticism of the ministry for being slow to crack down on cell phones and the neglect of police officials at the local level to enforce the ban on the trade in grain crops.²⁶⁴ Chu Sang-song gained prominence in 1970 when he became a candidate member of the Central Committee and a full member in 1991. He also worked as a member of the SPA in 1990 and 1998. A former front-line army corps commander (Fourth Corps), Chu's appointment fit with a trend of appointments within the security establishment of officials with operational military experience. In the years that followed, the mandate of the MPS began to grow as it benefited from the reestablishment of the KWP Administrative Department.²⁶⁵ Responsibilities that had once belonged to the KWP Organization

262 Before his appointment in July 2003, Choe Yong-su had been the chief of the KWP Organization Guidance Department's Public Prosecutors Department. The duty of this department was to investigate and monitor the Central Prosecutor's Office. In this post, Choe would have worked directly for Jang Song-taek.

263 Jang Song-taek was removed from his post as first vice director of the KWP's Organization Guidance Department allegedly as part of a power struggle with Ko Yong-hui, Kim Jong-il's wife, who was actively engaged in laying the foundation for the succession of one of her sons. It is also possible that Jang had disagreed with Kim Jong-il's more hard line economic policy. See "North Korea Appoints New Police Chief," *Yonhap*, 10 July 2004.

264 Within the same month, Col. Gen. Chi Yong-chun replaced Sim Won-il as head of the ministry's Political Department. Until this appointment, Chi was a vice director of the KPA's General Political Department. Sim's removal is interesting since there were rumors that he was not a supporter of the previous minister, Choe Yong-su.

265 In 2007, possibly in response to the death of the KWP Secretary for Public Security, Kye Ung-tae, Kim Jong-il reinstated the KWP Administrative Department, placing his brother-in-law Jang Song-taek at its head. This department has direct oversight responsibility for the internal security apparatus. Before his purge in 2004, Jang Song-taek oversaw the functions of the Administrative

Guidance Department, such as the “social cleanup” drive designed to eradicate corruption and roll back the reforms of the 1990s, were transferred to the Ministry of People’s Security.

When Won Ung-hui, the commander of the Military Security Command, died in May 2004, he was replaced by another military officer with front line experience. Col. Gen. Kim Won-hong had been a political commissar in both the Seventh and Ninth corps, as well as with the Pyongyang Defense Command, which has Praetorian Guard functions. But Kim did not share his predecessor’s close ties to Kim Jong-il and the Security Command, according to some sources, and lost much of the influence it garnered through its struggles with the SSD in the 1990s.²⁶⁶ In 2005, Kim Won-hong was reportedly demoted to lieutenant general for failing to effectively manage telephone use by foreign trade firms operated by the KPA in the wake of the bird flu outbreak.²⁶⁷ He was promoted again to colonel general in April 2009, a possible indication that the Military Security Command may have regained some of its stature. According to some South Korean reporting, Kim was replaced by Cho Kyong-chol during this period.²⁶⁸

The State Security Department (SSD) also appeared to recover from its entanglements of the 1990s. In 2008 and 2009, the SSD figured prominently in rare central media coverage of espionage activities within the country. Pyongyang’s use of the

Department, which at that time were folded into the KWP’s Organization and Guidance Department. According to one source, since his return, Jang has been populating the Administration Department with many of his protégés from his days as head of the Central Committee’s Youth Affairs Department.

266 “Reinstatement of Kim Jong-il’s Brother-in-Law, Jang Song-taek,” *Yonhap*, 17 March 2008.

267 The South Korean media carried numerous reports of the avian influenza outbreak in North Korea, something that embarrassed Kim Jong-il and the North Korean leadership. See “North Korea Limits International Phone Services After Bird Flu Outbreak,” *Yonhap*, 13 May 2005.

268 “Three ‘Angels of Death’ Behind Purge of DPRK Generals,” *Chosun Ilbo*, 23 March 2012.

secretive and reportedly brutal SSD—in its first ever observed appearances in central media—to deliver public messages is likely an intimidation tactic reflecting the regime’s seriousness about regaining control and restoring order. The SSD also took a high profile in the tightening of the regime’s internal control following Kim Jong-il’s stroke in August 2008. The SSD allegedly took the lead in monitoring and tracking the senior leadership in the months after the stroke to ensure loyalty.²⁶⁹ In April 2009, U Tong-chuk, the deputy director of the SSD, who presumably succeeded Kim Yong-yong, was promoted to colonel general.

Capture of Euna Lee and Laura Ling

Two American journalists, Euna Lee and Laura Ling, were detained along the Sino-North Korean border by North Korean soldiers in March 2009 as they were investigating a story on North Korean refugees in the border area. According to the Korean Central News Agency, they were detained for “illegally intruding” into North Korean territory after crossing the border from China.

Subsequent reporting suggested that the SSD took the lead in luring the two journalists into a trap. Ryu Kyong, the chief of the SSD’s second (counterespionage) bureau, reportedly paid overseas operatives in China to bribe a Korean guide to lead the two women to the banks of the Tumen River, where they were abducted and taken across the border into North Korea.

The two journalists were kept in detention until August 4, 2009. Lee and Ling were pardoned by the North Korean government after a special humanitarian visit by former US President Bill Clinton. During Clinton’s visit, Kim Jong-il hosted a dinner in his honor. U Tong-chuk, according to the North Korean media, attended the dinner.

269 “North Korea: Wipe Out Three Forces Facing the System,” *DongA.com*, 3 December 2008.

The Ministry of People's Security was again in the news at the end of 2009. In anticipation of social unrest caused by the currency revaluation,²⁷⁰ the regime began to raise the profile of the national police force.²⁷¹ On November 22, Kim Jong-il inspected the MPS headquarters, expressing his "great satisfaction" to public security officers for "performing the assigned combat mission in a responsible manner." This was the first time that Kim made such a publicized visit to the main office of the MPS.²⁷² In addition to this public relations move, some of the measures the regime took to deal with this crisis included: tightened travel restrictions, stepped up personal background checks, increased household checks for contraband and illegal

270 In November 2009, Pyongyang announced a currency redenomination, the fifth time it has taken such an action and the first time in seventeen years. Done in an apparent effort to curb inflation and bring the middle class under control as the regime lays the foundation for the upcoming succession, this move has caused great consternation within North Korea as people's savings and hidden assets were all but wiped out.

The sensitivity surrounding this move was highlighted by the central media's silence on the 100-to-one revaluation of the North Korean won that was implemented on November 30. On the previous four occasions in which the regime revalued the currency, the central media was forthcoming about the government's action—a "people's committee ordinance" in 1947 (one-to-one revaluation), a "cabinet decision" in 1959 (100-to-one revaluation), and "Central People's Committee decrees" in 1979 (one-to-one revaluation) and 1992 (one-to-one revaluation). This analysis of previous North Korean currency revaluation is based on reporting by the Open Source Center.

Pyongyang not only revalued the currency (won), but the amount of money people were allowed to exchange for the new currency was apparently limited to approximately 100,000 per person. According to some sources, foreign reporting may be confused on this issue. If history is any indication, the official announcement accompanying the 1992 revaluation allowed for a banking option that protected deposited funds above the amount exchanged. But the reports of violence since the revaluation would suggest that many people lost hidden funds, which cannot be recouped.

271 According to some media reports, the ministry's profile was raised over a year before when the KWP Central Committee augmented its authority, giving the MPS the authority to investigate "every criminal offense committed by the military, the SSD, and the public prosecutors and cadres of courts." *DailyNK*, 11 July 2008.

272 In fact, this apparently was the first ever publicized visit by Kim to a headquarters of any ministry. See "Leader Inspects Headquarters of People's Security Ministry," DPRK Radio, 22 November 2009. While all the details of the ministry's apparent elevation are not currently known, some Pyongyang watchers believe that Kim has taken steps to reestablish the balance of power that existed within the internal security apparatus before the MPS's demotion in the late 1990s.

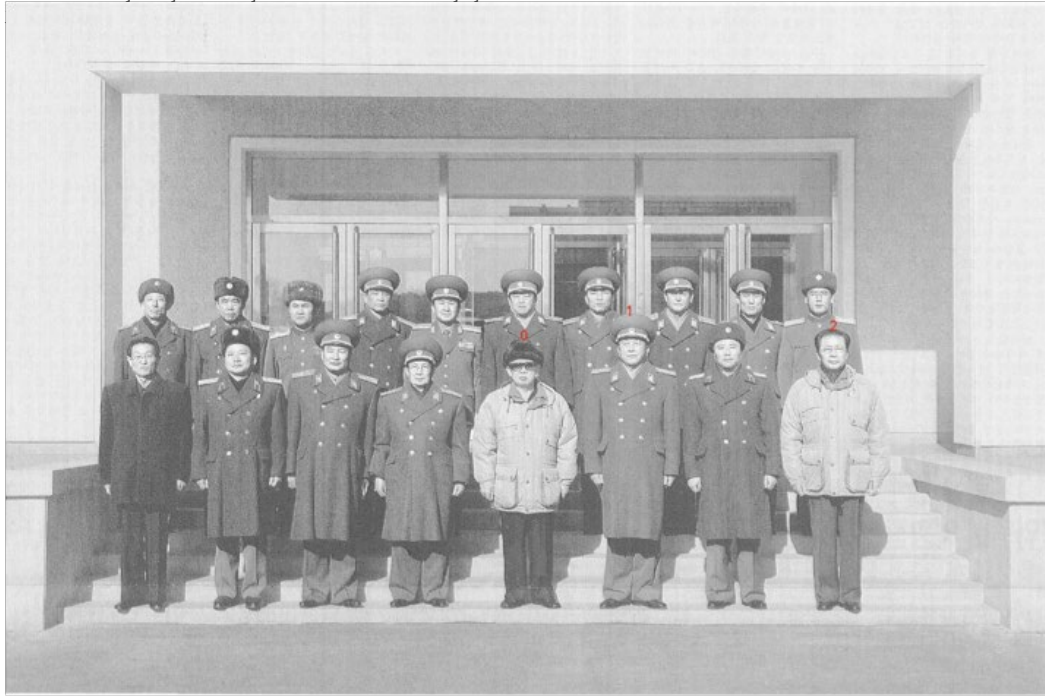

Photograph commemorating Kim Jong-il's November 2009 inspection of the Ministry of Public Security headquarters. 0-Kim Jong-il, 1-Chu Sang-song, 2-Jang Song-taek. (Nodong Sinmun, 22 November 2009).

In December, Gen. Chu Sang-song traveled to China to meet his counterpart, the first such trip by a Minister of People's Security since 1998. It is likely that this visit was largely driven by Pyongyang's currency revaluation. Gen. Chu's arrival in Beijing was underscored by North Korea's announcement that it was closing its border from late December (which is not uncommon) until February (which is unusual). Both sides reportedly discussed strategies to prevent defections associated with the currency revaluation, as well as illegal trading and drug trafficking. Gen. Chu also signed several agreements with his Chinese counterpart, Minister of Public Security Meng Jianzhu, which allegedly involved information sharing and the Chinese provision of

“aid materials” such as surveillance equipment and additional border fences. Additionally, Gen. Chu might have requested Chinese cooperation regarding the use of cellular phones in North Korea, which require base stations in Chinese border counties. Defectors in South Korea are able to talk with family members in North Korea using cellular phones in this way. The North Korean delegation may have discussed the issue of adjusting the distance between the base stations and the border so that cellular calls cannot get through to North Korea.

Cell Phone Crackdown

In Secheon-Dong, Hoeryong City, North Hamgyong Province, a worker at the local Grain Policy Enterprise was arrested for the murder of a security agent who was trying to find illegal cell phone users. After an investigation by the city security department, it came to light that the worker, Kim Kyung-chul, had begged the agent not to report his possession of a cell phone. When the agent persisted in his threat to report Mr. Kim, the worker, knowing the punishment for possession of a cell phone, killed the agent with a hatchet. Eventually, the city security department arrested Mr. Kim, along with his wife, his brother, and his three-year-old son. The family was sent to the “22nd Unit” labor detention center.

The City Security Department issued a formal resolution that it would crack down on possession of illegal cell phones in Hoeryong City. To this end, the Security Department launched a campaign in Hoeryong City to make people voluntarily report the possession of any cell phones between April 15th and the Day of the Sun (the birthday of Kim Il-sung)

Source: “Security Agent Murdered While Trying to Confiscate a Cell Phone in Hoeryong City” Good Friends: North Korea Today 339: April, 2010-07-15

In April 2010, the North Korean media hinted at a fundamental change in the command and control of the internal security apparatus. The name of the Ministry of People’s Security was altered in a way that suggests that it was formally elevated

in the regime’s organizational hierarchy.²⁷³ If true, this renaming suggested that the ministry was removed from the Cabinet apparatus and now reported directly to the NDC. This move was in keeping with the increased importance Kim Jong-il placed on internal security as the regime dealt with political transition and such crises as the failed currency devaluation of November 2009.²⁷⁴

The two charts below show the shift in institutional oversight of the internal security apparatus and the realignment of the Ministry of People’s Security:

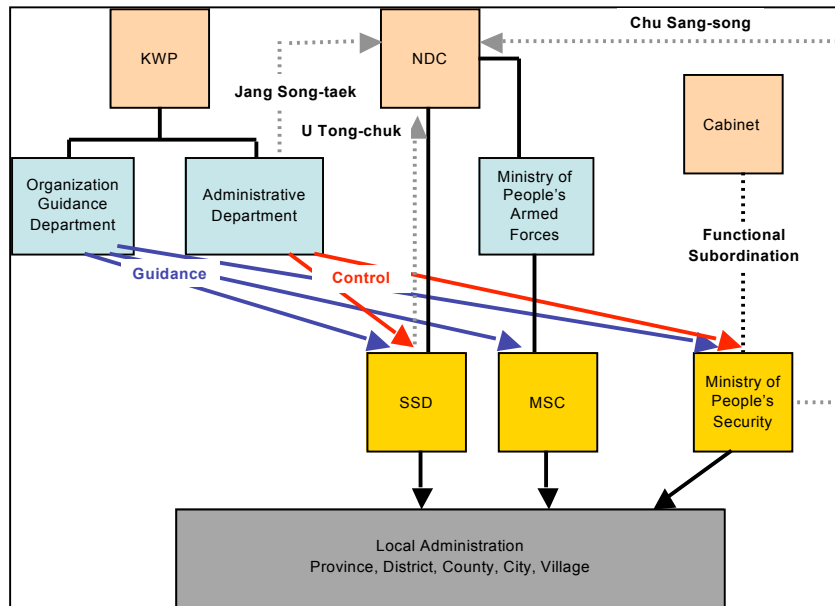

273 In an April 5 central television report on the Ministry of People’s Security, the Korean word for “ministry” was changed from “seong” (*In-min Bo-an-seong*) to “bu” (*In-min Bo-an-bu*). The standard Korean word for “ministry” used to describe institutions within the Cabinet apparatus has traditionally been “song.” Only two ministry-level institutions use the appellation “bu,” the Ministry of People’s Armed Forces (*In-min Mu-ryeok-bu*) and SSD (*Gukga An-jeon Bo-wi-bu*), and both are directly subordinated to the NDC. “Rapid Rise of North’s Ministry of People’s Security—Sign of Full-Scale Control Over Residents,” *Yonhap*, 06 April 2010.

274 “North Korea Upgrades Police Organ in Apparent Bid to Tighten Grip on Economy,” *Yonhap*, 06 April 2010.

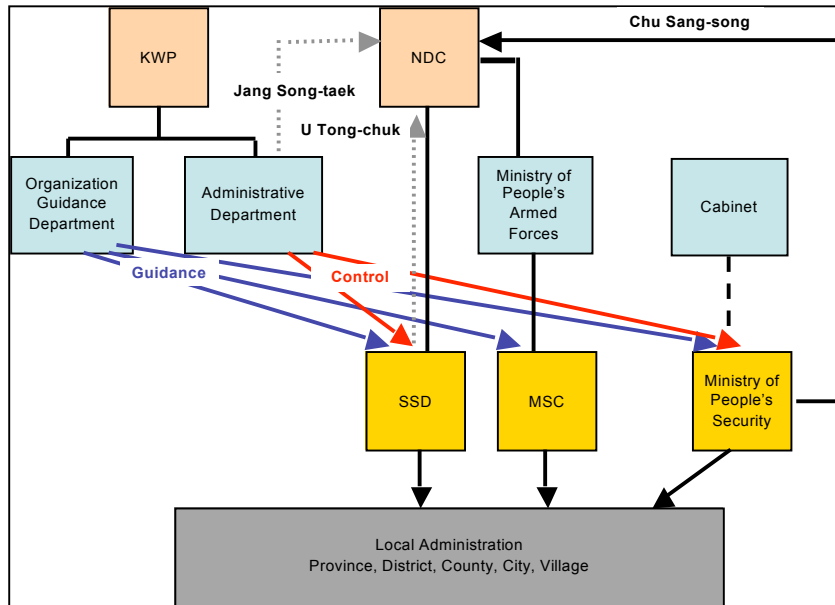

In June 2010, Kim Jong-il continued to fortify the state of the internal security apparatus. At a special meeting of the Supreme People's Assembly, the delegates rubber stamped the promotion of Jang Song-taek to the position of vice chairman of the NDC. His promotion to one of only four vice chairmen—a post previously held only by military leaders—not only strengthened the command and control of the internal security forces in a time of dissent within the regime following the currency revaluation debacle, but most likely signified an elevation in the status of police forces vis-à-vis the party and the military. This heightened influence allowed Jang to balance the often contentious relations among the internal security organs. As if to emphasize Jang's new role, the North Korean media began to make special mention of his post as “Vice Chairman of the NDC” and listed him ahead of KWP secretaries in stories. Before his promotion, Chang had been listed among the KWP department directors, even though he was a member of the NDC.

Laying the Groundwork for Kim Jong-un's Succession

As the international community began to opine on Kim's deteriorating health and the growing responsibilities of the NDC vice chairmen, the Chosun Central News Agency (KCNA) suddenly announced on June 26th that "the Politburo of the Central Committee would summon a delegates conference at the beginning of September to elect the leading apparatus of the Workers' Party." While the conference was delayed until the end of September, it formally laid the foundation for the post-Kim Jong-il succession. Not surprisingly, central to this evolving leadership configuration is North Korea's internal security apparatus.

Shortly before noon on September 28th, Kim Jong-il entered the undisclosed assembly hall to the cheers and a standing ovation of the Third Party Conference delegates. Walking toward the center of the rostrum, Kim took his seat, which faced the filled auditorium. Behind him was a large, marble statue of Kim Il-sung. In the front row of delegates, one seat in from the right aisle was Kim Jong-un, who was dressed in a dark Mao suit and hairstyle reminiscent of photographs of his grandfather taken in the 1940s. Seated to the heir apparent's right was Kim Won-hong (the former commander of the Military Security Command and future director of the State Security Department).²⁷⁵

275 Ken E. Gause, *North Korea Under Kim Jong-il: Power, Politics, and Prospects for Change*, op. cit.



Kim Jong-un at the Third Party Conference (September 28, KCNA). To his right is Kim Won-hong.

The security services figured prominently in the appointments made at the Third Party Conference. Chu Sang-song was appointed a full member of the Politburo, while U Tong-chuk and Kim Chang-sop, the director of the SSD Political Bureau, became alternate members. Kim Won-hong and U Tong-chuk were both appointed members of the Central Military Committee, a body whose status dramatically increased with the appointment of Kim Jong-un as one of its two vice chairmen. Finally, Jang Song-taek was made an alternate member of the Politburo and a member of the Central Military Committee.

In the months following the party conference, reports began to surface that Kim Jong-il's health had improved. The public relations campaign surrounding the succession slowed down to a more deliberate pace and rumors began to emerge from within North Korean leadership circles that Kim had begun to focus on how to ensure the long-term survival of his heir after his demise. Speculation had been rampant since Kim Jong-il's stroke in 2008 that any collective leadership that was built around Kim Jong-un would be shaky at best and most likely would relegate the

heir apparent to figurehead status. Even the loyalty of the Kim family, most notably Jang Song-taek, was questionable.²⁷⁶ In order to put the succession on a surer footing, Kim Jong-il in 2011 took a number of actions to rewire the loyalties within the internal security apparatus and thus make it more difficult for Jang Song-taek or any other member of the senior North Korean leadership to assume more power than that accorded to his own chosen successor.

The first indication of this strategy took place in January 2011 with the dismissal and alleged execution of Ryu Kyong, the SSD's vice director and chief of the second (counter espionage) bureau. Ryu oversaw approximately 50,000 counterintelligence agents dedicated to ferreting out spies and dissidents within the regime. His close ties to Kim Jong-il and his growing power were reflected in his promotion to colonel general on the eve of the Third Party Conference. His rising status, however, made him a natural rival of both Jang Song-taek and U Tong-chuk. In addition, his pervasive presence within the secret police apparatus reportedly made it difficult to carve out a role for Kim Jong-un, who has increasingly been tied to the organization.

According to sources inside North Korea, Ryu was summoned to one of Kim Jong-il's residences where he was arrested by the General Guard Bureau. He was later interrogated and "secretly executed."²⁷⁷ His removal was followed by the purge of over 100 SSD personnel. While some sources suggested that Ryu was removed for "being a double agent," the more likely cause is probably tied to succession politics.

276 Neither Jang Song-taek nor his wife, Kim Kyong-hui, has close ties to the children of Ko Yong-hui. In 2009, Jang reportedly shifted his loyalty from Kim Jong-nam to Kim Jong-un in return for Kim Jong-il's permission to rebuild his patronage network. See Ken E. Gause, *North Korea Under Kim Jong-il: Power, Politics, and Prospects for Change*, op. cit.

277 "Exclusive on Alleged Purge of DPRK Security Head Ryu Kyong," *NKChosun.com*, 20 May 2011.

Senior defector sources in South Korea suggest that Ryu's "sacrifice" might have been tied to Kim Jong-il/Kim Jong-un's efforts to secure U Tong-chuk's loyalty and support.²⁷⁸ If this speculation is true, the view that U Tong-chuk belongs to the Jang Song-taek patronage network may no longer hold true.²⁷⁹ While he no doubt reports up to Jang in the formal chain of command, U is also in a position to serve as a counterweight to Jang's power within the security apparatus or, at the least, to provide the heir apparent with situational awareness of his uncle's activities.

In 2011, both Kim Jong-un and U Tong-chuk were featured prominently in SSD-related events profiled in the North Korean media. On 15 April, Kim Jong-un was listed as one of his father's cohorts at a performance of the Art Squad of KPA Unit 10215, which is reportedly tied to the SSD.²⁸⁰ The next month, U Tong-chuk took part in a high profile meeting between Kim Jong-il and a delegation led by M.Y. Fradkov, the director of Russia's External Intelligence Bureau.²⁸¹

278 Author's discussions in Seoul in May 2011. According to defector sources, while the General Guard Bureau carried out the arrest, U Tong-chuk oversaw the operation. These same sources contend that U has "recently shifted his complete support to Kim Jong-un."

279 Many South Korean and Chinese Pyongyang watchers placed U Tong-chuk in Jang Song-taek's patronage network as late as 2010. They based this assessment on defector accounts and U's rise in prominence after Jang's return from banishment in 2007.

280 Some sources go so far as to suggest that this unit designator actually refers to the SSD based on previous Kim Jong-il inspections, including one in October 2010, weeks after the Third Party Conference, which included Kim Jong-un, U Tong-chuk, and Kim Chang-sop. See "Jong Un Attends Guidance of SSD (MSS) Unit," *North Korea Leadership Watch*, 26 October 2010.

281 According to several sources, including an essay in *Sapio* by Masaru Sato, Kim Jong-un met Fradkov and other officials. If true, most likely U served as the heir's main escort.



Kim Jong-il posing for a photograph with the Russian delegation, led by M.Y. Fradkov, head of the Russian Federation's External Intelligence Bureau. U Tong-chuk (circled in red), stands in the back row. (KCNA, 18 May 2011) This was Kim's first meeting with a senior Russian official since 2006. It was his first-ever public meeting with a foreign intelligence chief.

Coming out of the Third Party Conference, the Ministry of People's Security appeared to be on the rise. Chu Sang-song's name was often mentioned in the North Korean media. In February 2011, he received a high profile Chinese delegation led by his counterpart Meng Jianzhu. The talks, which included Kim Jong-il, reportedly focused on border security and the democracy protests in the Middle East and strategies to prevent the spread of similar movements in China and North Korea.



Chu Sang-song (KPA Gen.), Minister of People's Security, greets Meng Jianzhu, China's Minister of Public Security, in Pyongyang on 13 February 2011 (Photo: KCNA).

In a March 16th National Defense Commission decree, however, Chu Sang-song was released from his post as Minister of People's Security due to illness.²⁸² Not only was this move surprising because of Chu's rising profile, it was highly abnormal for a member of the KWP Political Bureau and the head of the police to be relieved from his post for the ambiguous reason of "personal problems."²⁸³ Outside speculation about the reasons for his dismissal was wide-ranging, from fallout due to Chinese protests over border security to a mysterious "Mangyongdae Incident" involving a protest near Kim Il-sung's birth home.²⁸⁴

282 "DPRK National Defense Commission Decision No 8," KCBS, 16 March 2011. The position remained unfilled until April when at the fourth session of the 12th SPA Ri Myong-su was appointed Chu's successor.

283 Interestingly, Chu was not publicly retired from his posts on the Politburo or the National Defense Commission.

284 "South Korean Government Confirms Top North Korean Security Official Dismissed for Mishandling China, North Korea Border Control," *Yomiuri Shimbun*, 9 April 2011; "Story of 'Man-

Regardless of the reason, the appointment of Chu's replacement, Ri Myong-su, appeared to have significant implications for the succession. Unlike Chu, who lacked a significant power base and whose allegiance to Jang Song-taek was ambiguous, Ri is a powerful figure in his own right with strong, enduring ties to Kim Jong-il. Before assuming administrative duties within the NDC,²⁸⁵ Ri was the director of the General Staff's Operations Bureau, an organization that Kim relied on to provide direction to the armed forces. According to some sources, Ri Myong-su was also one of the first members of the high command to throw his support behind Kim Jong-un.²⁸⁶ According to South Korean sources, he became one of Kim Jong-un's mentors soon after his designation as heir apparent in 2009.²⁸⁷

gyongdae Incident' That Led to Sacking of North's People's Security Minister," *Chosun Ilbo Online*, 9 April 2011.

285 According to one source, Kim Jong-un was groomed as the successor in the NDC Administrative Bureau. "Kim Jong-il's Son Effectively Controls Security Forces," *Chosun Ilbo Online*, 13 April 2011.

286 As a former chief of staff of the Third Corps and head of the GSD's Operations Bureau, Ri Myong-su has a unique understanding of the command and control nodes for Pyongyang. This knowledge, combined with his control of the MPS, will make him an important player in any future succession scenario.

287 During this time, Kim received "successor training" at the Administration Bureau of the National Defense Commission, which was run by Ri Myong-su.



Chinese Ambassador to North Korea Liu Hongcai (L) stands with the Minister of People's Security Ri Myong-su at Mansudae Assembly Hall, Pyongyang, on 10 May 2011 (Photo: PRC Embassy in DPRK).

In addition to the turnover at the top of the SSD and MPS, reshuffles were taking place at the provincial level. Reports began to surface in 2010 of a generational turnover in the internal security apparatus. Officials in their 40s are being replaced by cadres in their 20s and 30s. In North Pyongan Province, according to one source, “the SSD office has between two and three men in their late 20s and early 30s whereas the MPS office is home to five or six agents in their 30s.” A source from Yangkang Province concurred, adding:

Just now in the local SSD, prosecutors' office, and MPS, early- to mid-30s people have been stationed in almost all posts. These early- and mid-30s people are even taking places as high as vice director of the city or county SSD.²⁸⁸

288 “Young Men Taking Over Security World,” *DailyNK*, 21 June 2011.

While the links between this generational turnover and Kim Jong-un were far from certain, the ages of many of the up and coming agents within the security apparatus suggested that it could be tied to the succession.²⁸⁹ This speculation was bolstered by rumors that the heir apparent had taken a prominent role in the activities of the security forces in the provinces, including taking the lead in an anti-corruption drive that led to the arrest of senior security officials (mainly from the SSD) for taking bribes to facilitate the escape of people to China.²⁹⁰

As for the Military Security Command, its profile continued to grow. Kim Won-hong was increasingly seen on guidance inspections and in the presence of Kim Jong-un. While the linkages between the heir apparent and the MSC were not made public, and were not even the subject of speculation, the fact that the regime was increasingly nesting the notion of the Party Center (i.e., Kim Jong-un) with Military First Politics suggested that the MSC would likely continue its vaunted status within the security apparatus.

289 South Korean reporting contends that Kim Jong-un undertook an audit of the MPS and SSD in order to appoint his supporters to key positions. "Jittery N. Korean Regime Forms Special Riot Police," *Chosun Ilbo Online*, 3 June 2011.

290 Strategy Page on North Korea, 7 November 2011.



Kim Jong-il and Kim Jong-un watching a joint exercise (Korean Central Television, 29 November 2011). Kim Won-hong (designated by the red circle) stands behind the director of the GSD Operations Bureau Kim Myong-kuk.

The Kim Jong-un Regime

On December 17, Kim Jong-il's seventeen year rule came to an end as he reportedly succumbed to a heart attack. Nearly 50 hours after the event, the North Korean propaganda apparatus sprang into action, informing the world of Kim's passing and proclaiming Kim Jong-un, 28, the "great successor." Moving at a rapid pace, the

transition of power appears to have moved smoothly as the young Kim received the title “Supreme Leader” (*Choe-go Ryeong-do-ja*) and was made (by Politburo proclamation) “Supreme Commander” (*Chosun In-min-gun Choe-go Sa-ryeong-gwan*) of the armed forces.

In the early days of the Kim Jong-un era, the security forces have been on prominent display. On the funeral list, Jang Song-taek (19), U Tong-chuk (25), Kim Won-hong (58), and Ri Myong-su (74) were listed among the first 100 members of a 232 member list. At the funeral procession on December 28, Jang Song-taek and U Tong-chuk accompanied Kim Jong-un as he walked beside the car carrying his father’s cabinet. In the new Leader’s first guidance inspections of military units across the country, Kim Won-hong was a constant presence.



Kim Jong-il’s Funeral Procession (Korean Central Television, December 28, 2011). Jang Song-taek is on the left side of the hearse behind Kim Jong-un. U Tong-chuk is at the rear right bumper of the hearse behind Ri Yong-ho, Kim Yong-chun, and Kim Jong-gak.

In April 2012, the regime made a number of personnel appointments at the Fourth Party Conference and the 5th Session of the 12th Supreme People's Assembly. Kim Jong-un was made First Secretary, a new post with all the powers of the previous General Secretary posting. He was also made Chairman of the Central Military Committee and First Chairman (another newly created post) of the National Defense Commission. Now he holds all the positions needed to run the Party, State, and Military. Kim Jong-il was made the eternal General Secretary of the Party and eternal Chairman of the National Defense Commission.



Ministry of People's Security Rally in April 2012 (KCNA)

These two meetings also provided more clarity on the growing importance of the internal security apparatus. Jang Song-taek was elevated to full Politburo status. Kim Won-hong was appointed as the director of the State Security Department (a.k.a. Minister of State Security), the first publicly identified holder of this post since the death of Ri Chin-su in the early 1980s. Kim was also appointed a full member of the Politburo, a member of the Central Military Committee, and a member of the National Defense Commission. Kim replaced U Tong-chuk, who was removed from

the NDC.²⁹¹ Ri Myong-su was also appointed as a member of the Politburo, Central Military Committee, and National Defense Commission—filling the spot on the NDC once occupied by Chu Sang-song. Ri Pyong-sam, the director of the KPISF’s Political Bureau was made an alternate member of the Politburo. Finally, the successor to Kim Won-hong as head of the MSC was not made public, but according to South Korean reporting, Cho Kyong-chol currently occupies that position.

Internal Security Apparatus’ Ties into the Senior Leadership (2012)

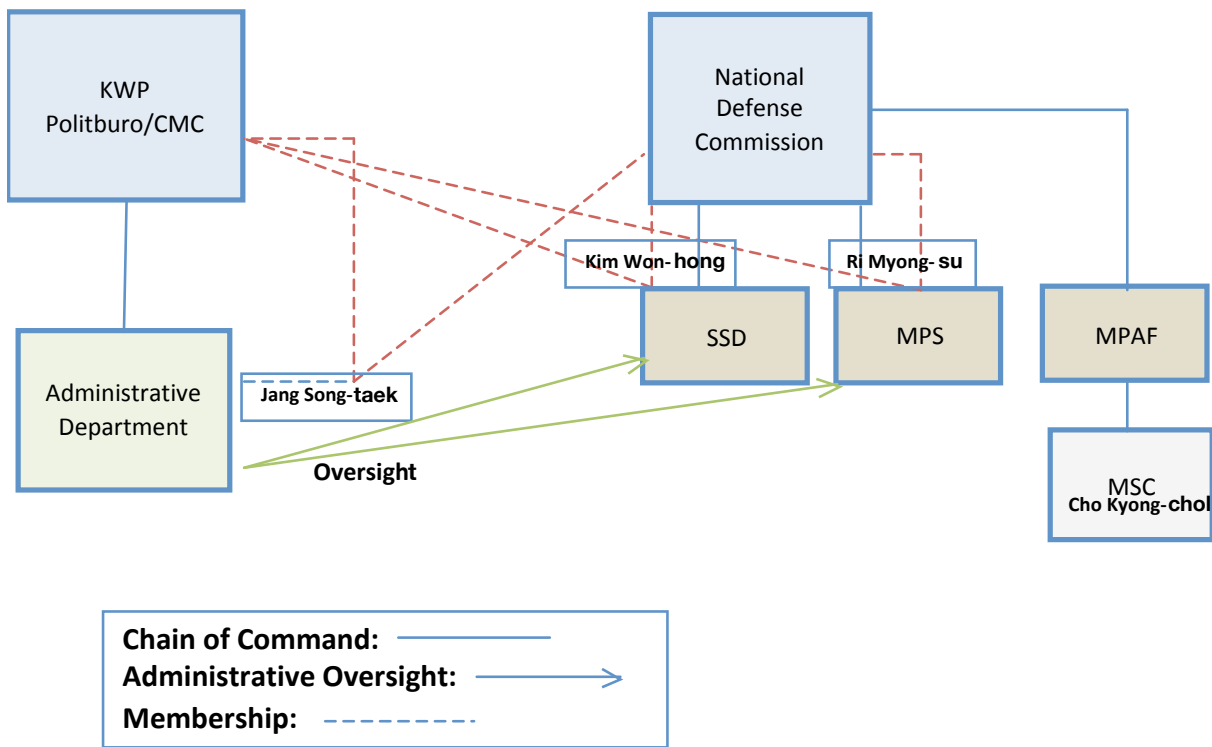

291 Some South Korean reporting has suggested that U Tong-chuk might have been purged or suffered a stroke, but as of this writing, there is no evidence of this. “N. Korea Purged Senior Intelligence Official,” Yonhap, 17 April 2012. Other sources have suggested that since U Tong-chuk is tied to the on-going purges taking place to ensure the Kim Jong-un succession, he has adopted a low profile.



Kim Jong-un inspection of Unit 3870 in January 2012 (KCNA). Kim Won-hong is third from the left.

Going forward, the Pyongyang watching community will pay close attention to how the regime is ruled. At present, it appears as if Kim Jong-un is ruling through a collective support network. Jang Song-taek, Kim Won-hong, and Ri Myong-su appear to be part of the inner rings of this network. Whether Cho Kyong-chol is part of this inner ring remains to be seen.

Rise of the Security Apparatus

Upon assuming power, Kim Jong-un sent some very clear signals that he does not intend (at least for the near term) to depart from the iron measures his father used to keep the country under control. Soon after Kim Jong-il's death, the regime allegedly posted an additional 20,000 soldiers along the border to tighten security and transferred full border authority to the SSD (which had previously shared it with the Ministry of People's Security).²⁹²

In the latter half of 2012, the security apparatus continued to be highlighted in a number of high profile events. At the beginning of October, a statue of Kim Jong-il was unveiled in front of the headquarters of the State Security Department (Ministry of State Security). Several days later, on October 6, Kim Jong-un visited the headquarters to view the statue. He also gave notice that public security control will be strengthened in North Korea with a directive to “firmly and mercilessly smash impure hostile elements.”

²⁹² For an assessment of the rise of the SSD, see Ahn Chan-il, “Raised Status of State Security Ministry & Its Operations,” *Vantage Point*, Vol. 35, No. 11 (November 2012). See also Brian Gleason, “Double Defectors: Signifiers of Pyongyang’s Strategic Shift,” *Sino-NK* website (December 2012).



The statue of Kim Jong-il in front of the SSD Headquarters (Photo: Nodong Sinmun, 06 October 2012)

Kim returned to the SSD headquarters on November 20 on the anniversary of the ministry's founding. He was accompanied by the SSD senior leadership, including Gen. Kim Won-hong and Col. Gen. Kim Chang-sop. Also in attendance was Jang Song-taek, Vice Chairman of the National Defense Commission and Director of the KWP Administration Department. KCNA reported that Kim "expressed the expectation that all the security personnel of the ministry would credibly fulfill their honorable mission to decisively frustrate the moves of the imperialists and reactionaries to stifle the DPRK by displaying the do-or-die will and matchless bravery."

After a photo-op, Kim was briefed “on the state security work and the progress made in the on-going operations from commanding officers of the ministry.”²⁹³



Kim Jong-un (center) is flanked by Col. Gen. Kim Chang Sop (seated, L), Director of the SSD Political Bureau, and Gen. Kim Won Hong (seated, R), Director of State Security (Photo: KCNA)

The Ministry of People’s Security also received its share of leadership attention. On October 5, MPS University, the ministry’s training and education facility, convened a campus-wide meeting “to vow to repay the deep trust and great loving care shown by Supreme Commander Marshal Kim Jong-un.” The ceremony was presided over by Col. Gen. Ri Pyong-sam, Director of the KPISF Political Bureau and alternate

²⁹³ “Kim Jong Un Visits the Ministry of State Security,” *North Korean Leadership Watch*, 20 November 2012.

member of the KWP Politburo. People's Security University Rector Kim Jang-kil delivered an official report in which he noted that Kim Jong-il visited the university on numerous occasions "clarifying specific issues ranging from the mission and duty of the university, educational contents and orientation of its development to educational conditions and supply service and reposing profound trust in it."²⁹⁴ The next day, on October 6th, the North Korean media announced that the Ministry of People's Security University was renamed the Kim Jong-il People's Security University. KCNA reported that the "renaming of the university is an event to be specially recorded in the history of the party and the revolutionary forces and a great event which witnessed the realization of the greatest desire of all teachers, cadets and all other service personnel of the Korean People's Internal Security Forces (KPISF)."²⁹⁵ By ascribing Chairman Kim's name to the university, which trains public security cadres, Kim Jong-un signaled both his highest confidence in the public security organ and his intention to strengthen public security control.²⁹⁶

294 KCNA, 06 October 2012 as reported in "People's Security University Renamed after KJI," *North Korean Leadership Watch*, 06 October 2012.

295 *Ibid.*

296 One Pyongyang watcher noted, "It is natural for Kim Jong-un, who is in the early stage of taking power, to strengthen public security control," and, "It looks like he is adding power to public security organs in particular lately, but, in fact, Kim Jong-un's hold on the public security organs started in 2009 when he was named successor."



*A satellite view showing the Ministry of People's Security and its educational facilities
(Google Image published on North Korean Leadership Watch)*

Several weeks later, in an unusual move, the regime chose to highlight the sacrifice of two MPS officers, who were posthumously awarded the title of Hero of the Democratic People's Republic of Korea. Kim Kum-su and Han Pyong-nam of the Kangwon Provincial People's Security Bureau were members of a team clearing explosives and unexploded ordnance in the province. On October 20th, as "they were working to defuse a time-bomb dropped by the U.S. imperialist aggressors during the Korean War, it went off... They died heroic deaths after saving their comrades at that critical moment." Kim Jong-un, himself, "put them forward as the most laudable men

trained by the Workers' Party of Korea and models of the security officers in the era of *songun*. He made sure that the shining end of the heroes and their worthwhile lives were always remembered by the people and showed the bereaved families profound loving care and solicitude to be conveyed down through generations."²⁹⁷ In a ceremony in Wonsan, SPA Presidium Vice President Yang Hyong-sop and Korean People's Internal Security Forces' Political Bureau Director Col. Gen. Ri Pyong-sam presented awards to the surviving family members.



Vice President Yang Hyong-sop presenting awards to the family members of the fallen MPS officers (KCNA as published on North Korean Leadership Watch)

²⁹⁷ KCNA, 27 October 2012, as cited in "DPRK Hero Title Posthumously Awards to People's Security Officers," *North Korean Leadership Watch*, 29 October 2012.

In November, the MPS convened a meeting for its branch chiefs at the 25 April House of Culture in Pyongyang. This was an event designed to express loyalty to the new Kim Jong-un regime. At the start of the meeting, a congratulatory message from Kim was read in which he “expressed firm belief that they would creditably discharge their honorable mission and duty as revolutionary armed forces of the WPK and internal security forces of the supreme commander.”²⁹⁸ Kim went on to urge the security forces to find and crush “rebellious people who are maneuvering behind the scenes to destroy our unity and prompt a riot.”²⁹⁹ Attending the meeting were Minister of People’s Security Gen. Ri Myong-su; Col. Gen. Ri Pyong-sam, Director of the Korean People’s Internal Security Forces’ Political Bureau; MPS and Provincial People’s Security officials; and “exemplary chiefs of branch social security stations across the country and people’s security personnel.” According to speeches by the participants, “the meeting would record a significant chapter in the history of the people’s security organ, which covered over six decades of shining victories and glory under the wise leadership and warm care of the peerlessly great persons of Mt. Paektu.” The speeches “noted that the branch social security station, cell of the people’s security organ and the lowest combat unit, has invariably taken the way of class struggle sharing its destiny with the Party in each chronicle of the revolution under the energetic leadership and benevolent care of the peerlessly great persons.”³⁰⁰

298 “Kim Jong Un Sends Congratulatory Message to People’s Security Personnel,” KCBS, 23 November 2012.

299 “N. Korean Leader Urges Crackdown on Rebellious Forces,” *Yonhap*, 24 November 2012.

300 Quotes taken from “People’s Security National Meeting Held,” *North Korean Leadership Watch*, 26, November 2012.



Photograph of Kim Jong-un with participants at a 23 November 2012 national meeting of branch chiefs of social and people's security stations (KCNA as published on North Korean Leadership Watch)

At the beginning of December, the North Korean regime capped its two month focus on internal security with a national meeting of judicial officials held at the People's Palace of Culture in Pyongyang. Part of a series of recent national gatherings of the country's internal security, police, legal and judicial organizations, the meeting was convened in observation of the anniversary of Kim Jong-il's 1982 essay "On Increasing Obedience to Socialist Laws."³⁰¹ In addition to senior SPA officials,

³⁰¹ "Judicial Officers Meeting Held," *North Korean Leadership Watch*, 05 December 2012.

the meeting included the Minister of People's Security Gen. Ri Myong-su and "other officials concerned, members of the Committee for Guidance in Socialist Law Observance at each level, judicial officers and model law explainers." The speakers stressed the need for all the judicial officials "to mercilessly smash the anti-socialist moves of the enemies by maintaining the steadfast revolutionary principles and working-class stand and make all the citizens strictly abide by the laws and regulations so that the sound and revolutionary spirit can prevail all over the society."³⁰²



From left to right: Yang Hyong-sop, Kim Yong-nam, Choe Tae-bok, and Gen. Ri Myong-su on the platform of the national meeting of judicial officers (Photo: KCNA/KCTV as published on North Korean Leadership Watch)

302 *Ibid.*

The meaning of this significant uptick in focus on the security apparatus was not entirely clear. However, it overlapped with rumors of purges, loyalty campaigns, and a crackdown to weed out “impure elements” among the population. According to a KCNA report, Kim Jong-un was cracking down on anti-government activities and had issued orders to security authorities to identify and deal with “dissidents.” In his message to the meeting of judicial officials, Kim stressed that ““We must find all of the notorious dissidents, who are hiding a knife behind their backs and waiting for the right timing to trigger a riot, and flatten all of them mercilessly.”

On a more political level, Kim and his allies within the leadership carried out a very public purging of the high command. By some accounts, this was the most extensive crackdown in 20 years. According to South Korean sources, more than 30 senior-level military officers were demoted or removed from their posts, including all four of the military figures who accompanied Kim Jong-un alongside his father’s hearse. In July, VMAR Ri Yong-ho, the powerful chief of the General Staff, was purged for apparently opposing Kim’s efforts to pivot away from the Military First (*songun*) Policy. He allegedly now resides under house arrest. Four months later, rumors began to surface that Kim Jong-gak had been released from his post as the Minister of People’s Armed Forces, a post he had assumed only six months earlier. Whether these moves are a sign of Kim’s growing power or growing paranoia is not clear at the time of this writing.

As 2012 came to a close, it became increasingly clear that the regime was pivoting from a leadership model centered on a Military First policy to one where the center of gravity has returned to the Party. As part of that shift, the internal security apparatus assumed a higher profile as it seeks “to eradicate impure elements” and strengthen public security rule.



In January 2013, Kim Jong-un convened a meeting of security officials to discuss the implications for the UN sanctions following the North Korea missile launch. Kim Won-hong was the only internal security official to take part in this meeting. (Photo: Korean Central Television, 27 January 2013)

In 2013, the focus on the internal security apparatus continued. Ri Myong-su dropped from sight in January. Three months later, at the Central Committee Plenum, the North Korean media announced that he had been replaced by Choe Pu-il,³⁰³ a first vice chief of the General Staff Department. Choe, who is considered close to Kim Jong-un and already a member of the KWP Central Military

³⁰³ According to the North Korean media, which provided a biographic profile of Choe on his appointment to the Politburo, he assumed command of the Ministry of People's Security in February. "Comrade Choe Pu-il: Alternate Member of the Political Bureau," *Nodong Sinmun*, 01 April 2013.

Committee,³⁰⁴ was appointed to the Politburo as an alternate member. Shortly thereafter, at the 7th Session of the 12th Supreme People's Assembly, Choe was appointed to the National Defense Commission. While Ri Myong-su has since reappeared in public, he is presumed by some Pyongyang watchers to have lost his seats on the Politburo and Central Military Commission.³⁰⁵ The North Korean media did announce his dismissal from the NDC.



Choe Pu-il speaking at the unveiling of statues of Kim Il-sung and Kim Jong-il at the Ministry of People's Security in April 2013. (Photos: Korean Central Television, 15 April 2013)

What does this all mean for the average North Korean? Sadly, the answer is probably not much. The regime has given no indication that it intends to embrace new, more humane policies towards the population. If anything, as the succession plays itself out, the regime will become even more vigilant against any anti-Kim sentiment and crackdowns along the border with China and efforts to root out

304 According to Pyongyang watchers in Seoul, Choe Pu-il, unlike his predecessor, is not close to Jang Song-taek and his appointment could have been designed to give Kim Jong-un more direct control over the internal security apparatus.

305 As has become customary over the last several Party leadership meetings, only appointments have been announced, not dismissals.

the “ill effects” of the markets will become commonplace as the leadership moves toward its destiny of becoming a “strong and prosperous nation.”³⁰⁶ According to one source, this is evidenced by the increase in the number of surveillance cameras along the border with China.³⁰⁷ Kim Jong-un has also allegedly given orders for harsher punishment (including execution) for defectors caught along the Sino-North Korean border.³⁰⁸

In his ongoing effort to consolidate political control following the death of Kim Jong-il, it appears that Kim Jong-un is employing the regime’s surveillance organs to tighten control over residents.³⁰⁹ According to a North Korean source,

Currently, the North Korean authorities are drastically strengthening control of the marketplace where all sorts of rumors are circulated... Recently, it is difficult to make a

306 According to Japanese reporting, “After the death of Kim Jong-il, an instruction was given that there should be no gathering of more than five people.” *Yomiuri Shimbun*, 20 December 2012.

307 Although surveillance cameras have been visible along the North Korean border since 2010, a source from Musan in North Hamkyung Province noted that “Starting this month [January 2012], more surveillance cameras have started being installed to improve security along the border. The surveillance cameras have been brought in larger numbers into areas where escapes and smuggling often used to happen.” The cameras are controlled by the Border Guards, but are monitored by the SSD. “NSA Ramping Up Use of Surveillance Cameras,” *The Daily NK*, 10 February 2012.

308 At the request of the North Korean government, China in 2011 reportedly carried out a widespread crackdown and deportation of Koreans living in Chinese cities along the border.”NK Urged China to Quickly Deport Defectors,” *Dong-A Ilbo*, 27 February 2012.

309 According to one South Korean report, Kim Jong-un has taken measures to enhance the crackdown and punishments related to defections. First, monitoring defector families has been extended beyond those living along to border to those living in the interior of North Korea. Second, orders have been issued to shoot to kill defectors who have escaped to China. In the past, the shoot to kill order was only issued for those attempting to escape North Korea, not to those who had already escaped. This is tied to a recent Kim directive that classifies defectors to China as traitors, a crime that carries the death penalty if the person is apprehended. These measures suggest that Kim Jong-un is attempting to stabilize the succession by strengthening internal control. Lee Kyu-chung, “North Korea’s Harsher Surveillance and Punishment of Defectors and Our Response,” KINU Online Series, 11-30, 2011.

phone call to the inside (of North Korea)...Rumor has it that large scale inspection teams have been dispatched to each region.

Only time will tell if these reports are true and if they indicate that Kim Jong-un will run the regime much as his father did—with an iron hand.

CONCLUSION

In 2012, the North Korean regime finds itself faced with many problems that threaten internal stability. Not only is the country facing another year of food shortages, but Kim Jong-il's death raises many questions about the regime's stability at the top. The information cordon that once surrounded the country has deteriorated and information about the outside world filters in through cell phones, DVDs, and surreptitious radio and television monitoring. North Korean leaders talk ceaselessly about efforts to pave the way for a "great and prosperous state," which will mark the 100th anniversary of the birth of state founder Kim Il-sung. But such a strategy seems doomed to failure by any stretch of logic.

Looking toward the future, many North Korea watchers have already begun to speculate about the eventual collapse of the Hermit Kingdom. How can it continue to defy gravity? Just as the Soviet Union collapsed and Mao's China evolved, certainly the Kim family dynasty cannot continue as it has living in the dark ages, refusing to join the community of nations. Or can it?

For sixty years, the internal security apparatus has ensured the survival of the Kim family dictatorship. Whether or not North Korea collapses, evolves, or continues to muddle through will depend a great deal on the viability of this all-pervasive apparatus. In recent years, rumors have begun to seep out through the defector community that cracks may have begun to appear in the repressive system—with security personnel more susceptible to bribes, discipline among provincial level police waning, members of the *inminban* turning a blind eye, and even the public taking retribution against members of the police force.³¹⁰ Is this an indication of the beginning of the

310 According to South Korean reporting, several provincial and city police officials were mur-

end? Unfortunately, with the opaqueness that surrounds the North Korean state, it is impossible to tell. At best, scholars and intelligence analysts can only watch and continue to piece together the puzzle. But, one thing is clear—as long as the regime continues to adhere to the tactics of a police state to hold onto power, human rights in North Korea will continue to be violated and the unfortunate citizens of the country will continue to live in the shadows.

dered in 2011 and 2012, including the chief of inspections for Tongdaewon District and the chief of police in Pyongchon District, two districts in Pyongyang. A special investigation team was formed, but was unable to find the culprit(s). See “High-Level North Korean Police Cadres Being Murdered Successively,” *Dong-A Ilbo Online*, 02 April 2012.

APPENDIX I: BIOGRAPHIES OF KEY INTERNAL SECURITY OFFICIALS



KIM WON-HONG (1945–)

- **Education:** Graduated from Kim Il Sung Higher Party School.
- **Career:** 1962: Joined the KPA. 1992: Deputy Director of the MPAF Political Security Defense Bureau. 1996: Deputy Commander of MPAF Security Command. 1997: Member of the State Funeral Committee for late Choe Kwang. 1998: Deputy to the 10th SPA. Political Commissar to the VII Corps. Political Commissar to the Pyongyang Defense Command. 2003: Deputy to the 11th SPA (election district no. 646). 2003 to 2009: Commander of the MPAF's Military Security Command. 2009: Deputy of 12th SPA, Member of SPA Credentials Committee. April 2009: Promoted to colonel general. February 2010: GPB Vice Director for Organization.
- **Current Position:** September 2010: Appointed as a member of the KWP Central Military Committee at the Third Party Conference. April 2012: Director of SSD, member of Politburo, member of Central Military Committee, and member of National Defense Commission.

Source: Ministry of Unification's Key Figures of North Korea 2009; Japan's Radiopress North Korea Directory 2007; and KCNA, 29 September 2010; "Brief History of DPRK Officials Elected to Fill Vacancies," KCNA, 11 April 2012.



U TONG-CHUK (1942–)

- **Education:** Graduated from Kim Il-sung University with a degree in philosophy.
- **SSD Career:** He entered the SSD after serving as a KWP Central Committee guidance officer and deputy section chief. He first served as director of the SSD's Foreign Intelligence Bureau and SSD deputy director and presumably became first deputy director of the SSD following the purge of Kim Yong-yong in the late 1990s.
- **Political Rise:** His name first appeared prominently in the North Korean press in 1992 when he was promoted to lieutenant general. He was elected as a member of the 11th and 12th SPAs. He again appeared in the press when he was promoted to colonel general in April 2009. In that same month, he was appointed to the NDC. He was promoted to general. His promotion to full general in one year is the quickest promotion to the grade in the Kim Jong-il era. At the Third Party Conference (September 2010), he was promoted to alternate member status in the KWP Politburo and made a member of the KWP Central Military Committee.
- **Current Status:** In April 2012 at the 5th Session of the 12th SPA, he was removed from the NDC, apparently replaced by Kim Won-hong. Rumors are he suffered a stroke and has been removed from all posts.

Source: Ministry of Unification's Key Figures of North Korea 2009; Japan's Radiopress North Korea Directory 2007; KCNA, 14 April 2010; KCNA, 29 September 2010; and Hisashi Hirai, Kitachosen no Shidotaisei to Kokei (Tokyo: Iwanami Shoten, 2011); and "Fifth Session of SPA Held," KCNA, 13 April 2012.



RI MYONG-SU (1934–)

- **Education:** Graduated from Kim Il-sung Military University.
- **Career:** Joined the KPA in 1950. November 1980: Director, the Revolutionary Victory Memorial Hall. December 1993: Chief of Staff, Third Corps. November 1996: Commander of KPA Corps. April 1997: First Deputy Chief of the General Staff Department and Director, the GSD Operations Department. July 1998: Deputy to the 10th Supreme People's Assembly. October 2000: General, the People's Army (current position). May 2007: Director, the Administrative Department of National Defense Commission. April 2011: Minister of People's Security. April 2012 (Fourth Party Conference): member of Politburo, member of Central Military Committee, and member of National Defense Commission. March 2013: Presumably removed from the Politburo. April 2013: Removed as Minister of People's Security and NDC.

Source: Ministry of Unification's Key Figures of North Korea 2010; and Japan's Radiopress North Korea Directory 2007; KCNA, 07 April 2011; "Brief History of DPRK Officials Elected to Fill Vacancies," KCNA, 11 April 2012. North Korean Media, March 31, April 1, 2013.



KIM CHANG-SOP (1946–)

- **Education:** Kim Il-sung Higher Party School.
- **Career:** Joined the People's Army in 1963. Instructor, chief instructor and deputy section chief of the KWP Central Committee and vice director of State Security and vice-director of its Political Bureau. Promoted to colonel general in August 2009.
- **Current Position:** 2009: Appointed director of the SSD Political Bureau. At the Third Party Conference (September 2010), he was promoted to alternate member status in the KWP Politburo.

Source: KCNA, 29 September 2010.



KIM PYONG-SAM (1935–)

- **Education:** Graduated from Kim Il-sung Military University.
- **Career:** Instructor, vice director, and director of the Political Department of a KPA Corps. Political Commissar of a KPA Corps. Vice Director of the General Political Bureau.
- **Current Position:** Vice Director of a Central Committee Department. Director of the KPISF Political Bureau. April 2012 (Fourth Party Conference): Alternate Member of the Politburo.

Source: "Brief History of DPRK Officials Elected to Fill Vacancies," KCNA, 11 April 2012.



CHO KYONG-CHOL

- **Birthdate:** Unknown.
- **Career:** A colonel general and former political commissar of the KPA Air Force.
- **Current Position:** According to South Korean reporting, he assumed command of the Military Security Command in 2009 around the time of Kim Jong-un nomination as heir apparent, although there is no North Korean reporting to confirm this claim.
- **Political Rise:** He began to appear in the North Korean media in 2012, accompanying Kim Jong-un on his inspection of Panmunjom (March). He was allegedly deeply involved in the purges of the high command that occurred in the lead up to the Fourth Party Conference.

Source: "Three 'Angels of Death' Behind Purge of DPRK Generals," Chosun Ilbo, 23 March 2012.



CHOE PU-IL

- **Birthdate:** March 6, 1944 in Hoeryong City, North Hamgyong Province.
- **Education:** Kim Il-sung Military University
- **Career:** Enlisted in KPA in 1962—serving in KPA Naval Command. Deputy chief of operations training center. Served in KPA Physical Culture Guidance Committee and managing the April 25 Sports Group. Brigade commander. Chief of staff of army corps. Promoted to Lieutenant General in 1995. Promoted to Colonel General in 2006. 2009: Vice Chief of the GSD and Chief of Coastal Security and Border Security bureaus. Commander of the IX Army Corps. First Vice Chief of the GSD and Director of the Operations Bureau.
- **Current Position:** September 2010: Member of Central Military Commission (Third Party Conference). March 2013: Alternate Member of the Politburo (KWP Central Committee Plenum). September 2010: Elected to KWP CC and promoted to General. April 2013: Member of NDC and Minister of People's Security (7th Session of 12th SPA).
- **Political Rise:** Choe's rise accompanied Kim Jong-un's own rise. He is rumored to have been a coach of one of North Korea's basketball teams where he was first noticed by Kim and his father. On 10 October 2010, Choe led the military parade held to celebrate the 65th anniversary of the foundation of the Korean Workers' Party.

Sourch: Rodong Sinmun, 01 April 2013; North Korea Leadership Watch.



JANG SONG-TAEK (1946–)

- **Education:** Educated at Kim Il-sung University.
- **Career:** July 1985: First deputy director, Youth Affairs Department of the Party Central Committee. November 1986: Deputy to the Seventh-11th Supreme People's Assembly [SPA]. April 1989: Director of Party Central Committee's Youth Affairs and Three Revolutions Teams Department. June 1989: Alternate member of the KWP Central Committee (CC). December 1992-present: KWP CC member. May 1994-2005: First vice director of KWP Organization and Guidance Department. January 2006: First vice director of the KWP Mass Organizations and Capital Construction Department. September 2010: Appointed Alternate Member of the Politburo at the Third Party Conference.
- **Current Positions:** December 2007-present: Director of the KWP Administrative Department. April 2009: Appointed member of the NDC at the 12th SPA. June 2010: Appointed Vice Chairman of the NDC at the 3rd Session of the 12th SPA. September 2010: Appointed Member of the Central Military Committee at the Third Party Conference. April 2012: Full Member of the Politburo.

Sources: Ministry of Unification's Key Figures of North Korea 2009 and KCNA, 29 September 2010; "Brief History of DPRK Officials Elected to Fill Vacancies," KCNA, 11 April 2012.



KIM PYONG-YUL (1926–)

- **Education:** Educated at College of Engineering, University of Prague.
- **Career:** November 1969: Chief Secretary of the North Pyongan Provincial Party Committee. November 1970-present: Member of the Korean Worker's Party Central Committee. December 1972-present: Deputy to the Fifth, Seventh, Eighth, 10th, and 11th Supreme People's Assembly. June 1985: Chief Secretary of the North Pyongan Provincial Party Committee and chairman of the North Pyongan Provincial People's Committee. June 1990: Director of an unidentified general bureau in the State Administration Council. October 1995: General of the Korean People's Army. Listed as #45 on Kim Jong-il's funeral committee.
- **Current Positions:** September 1998-present: Member of the SPA Legislation Committee. September 1998-present: President of the Central Court.

Source: Ministry of Unification's Key Figures of North Korea 2009; and Japan's Radiopress North Korea Directory 2007.



CHANG PYONG-KYU

- **Birthdate:** Unknown.
- **Career:** April 2010: Appointed Director of the Supreme Public Prosecutors Office at the Second Session of the 12th SPA. April 2010-Present: Prosecutor General. September 2010: Appointed Alternate Member of the KWP Central Committee. April 2011: Chairman of the SPA Legislation Committee.

Source: North Korean media reporting.

Previous Security Leaders



CHAE MUN-TOK (1943–)

- **Career:** October 1983: Vice Minister of Public Security. October 1985: Director, the Pyongyang Municipal Security Department. November 1995: Director, the Political Department in the Ministry of Public Security, Colonel General of the People's Army. July 1998: Deputy to the 10th Supreme People's Assembly. April 2000: Dismissed from the post of director of the Political Department, the Ministry of People's Security.

Source: Ministry of Unification's Key Figures of North Korea 2009; and Japan's Radiopress North Korea Directory 2007.



CHOE YONG-SU (1950–)

- **Education:** Kim Il-sung University.
- **Career:** July 2003-2004: Minister of People's Security. August 2003: Deputy of 11th Supreme People's Assembly. September 2003-2004: Member of the National Defense Commission. September 2003: Chairman of the SPA Legislation Committee. July 2004: Dismissed as Minister of People's Security (replaced by Chu Sang-song) reportedly in connection with the explosion near Ryongchon in April 2004.

Source: Ministry of Unification's Key Figures of North Korea 2009; and Japan's Radiopress North Korea Directory 2007.



JANG SONG-U (1935–August 2009)

- Education: Educated at Kim Il-sung University.
- **Career:** October 1980: Member of the Workers' Party of Korea [WPK] Central Committee. February 1982: Deputy to 7th-11th Supreme People's Assembly [SPA]. 1988: Director of Reconnaissance Bureau in the Ministry of People's Armed Forces. January 1989: First Vice Minister of Public Security. December 1991 – November 1995: Director of Political Department in the Ministry of Public Security. April 1982: KPA general. October 1994: Commander of Third Corps. October 1995: Director of Security General Bureau. August 1997: Commander of Third Corps. April 2002: KPA vice marshal. August 2003: Deputy to the 11th Supreme People's Assembly (Constituency No. 134).

Source: Ministry of Unification's Key Figures of North Korea 2009; and Japan's Radiopress North Korea Directory 2007 and North Korean reporting.



CHOE WON-IK (1928–2001)

- **Career:** May 1969: Director, the General Political Department in the Ministry of National Defense. December 1972: Deputy to the Fifth, Sixth, Ninth and 10th Supreme People's Assembly. December 1976: Minister of Public Security. July 1984: Vice chairman, the South Hamgyong Provincial People's Committee. December 1985: Standing Vice Chairman, the South Hamgyong Provincial People's Committee. December 1992: President of the Central Court. April 1993: Member, the Legislation Committee of the Supreme People's Assembly. November 1998: Chief Secretary of the Kangwon Provincial Party Committee.



CHON MUN-SOP (1921–1998)

- **Education:** Attended a Soviet military school.
- Participated in Kim Il-song's guerrilla unit prior to liberation.
- **Career:** April 1956: Commander of the 10th Division of the KPA. 1956: Seventh Corps Commander. August 1960: Commander of the Second Corps of the KPA. November 1960: Commander of the Kaesong District Garrison. June 1961: Commander of the Second Military Task Force (Colonel General). September 1961: member of the Party Central Committee. October 1962: Deputy to the Third to 10th Supreme People's Assembly. 1964: Vice Minister of Public Security and Director of the Guard Bureau. November 1969: awarded title of Hero of the Republic and Order of National Flag First Class. November 1970: member of the Party Central Committee. April 1975: Director, the Security General Bureau. December 1977: Member of the WPK Central Committee Political Bureau. July 1984: Chairman, the State Control Committee. May 1988: Vice minister of the People's Armed Forces. October 1989: Chairman, the DPRK Anti-Imperialism Veteran Fighters Committee. April 1993: Chairman, the State Control Committee, September 1998: Honorary vice president, the Supreme People's Assembly Presidium.

Source: "Biographic Sketches of DPRK Leaders," op. cit; Ministry of Unification's Key Figures of North Korea 2009; and Japan's Radiopress North Korea Directory 2007.



CHU SANG-SONG (1933–)

- **Career:** November 1970: Alternate member of WPK Central Committee. April 1990: Deputy to Ninth and 10th Supreme People's Assembly. December 1991: Member of WPK Central Committee. April 1992: Colonel General of the People's Army. February 1997: General of the People's Army. February 1997: Corps commander. July 2004-2011: Minister of People's Security. April 2009: Member of the National Defense Commission. September 2010: At the Third Party Conference, promoted to full membership status in the KWP Politburo. March 2011: Retired as Minister of People's Security by NDC decree. Presumably he has lost his position on the Politburo.

Source: Ministry of Unification's Key Figures of North Korea 2009; and Japan's Radiopress North Korea Directory 2007; KCNA, 29 September 2010; KCNA, 16 March 2011.

KIM PYONG-HA (?–1981)

- **Birthdate:** Unknown
- **Career:** Kim Il-sung's adjutant. November 1970, KWP CC Member. 1971: Minister of Public Security. 1977-1981: Director of the State Political Security Department.
- Committed suicide in 1981.

Source: "Biographic Sketches of DPRK Leaders," op. cit.

KIM YONG-RYONG (early 1940s–1998)

- **Education:** Educated at Kim Il-sung University.
- **Career:** 1960s: Chief of the North Hamgyong Provincial SSD. 1970s: State Security Department Headquarters. 1987: First Deputy Director of the State Security Department. 1991: KWP CC Alternate Member. 1992: KWP CC Member. 1992: Promoted to Colonel General. 1994: Member of Kim Il-sung Funeral Committee. 1995: Member of O Jin-u Funeral Committee. 1997: Promoted to General.
- Committed suicide in 1997 or 1998.

Source: "Biographic Sketches of DPRK Leaders," op. cit. "DPRK Purges Officials Critical of Government," Yonhap, 06 November 1998.

**KYE UNG-TAE** (1925–2006)

- **Education:** Educated at the Soviet Higher Party School.
- **Career:** November 1967: Deputy to Fourth-11th Supreme People's Assembly. December 1967: Minister of Foreign Trade. November 1970: Member of the KWP Central Committee. December 1975: Deputy premier of the Administration Council. November 1985-2006: KWP Secretary in charge of public security. December 1986: Chairman of the SPA Legislation Committee. March 1988: Member of the KWP CC Political Bureau.

Source: Ministry of Unification's Key Figures of North Korea 2009; and Japan's Radiopress North Korea Directory 2007.



O YONG-PANG (1930–2000)

- **Career:** November 1970: KWP Central Committee Alternate Member. January 1975: Director of the MPAF Security Bureau, Lieutenant General. October 1980: KWP Central Military Commission Member (current position). February 1982: Deputy to the 7th-8th, 10th Supreme People's Assembly (current position). February 1986: KWP Central Committee Member. May 1992: Vice Chairman of the North-South Joint Military Committee. October 1994: Deputy Chief of General Staff of the MPAF. October 1994: KPA General. April 1996: Vice Minister of the MPAF. September 1998: Vice Minister of the MPAF.

Source: Ministry of Unification's Key Figures of North Korea 2009; and Japan's Radiopress North Korea Directory 2007

PANG HAK-SE (1914–1992)

- **Birth and education:** Born Pang Nicholai Ignatievich in 1914 in small town of Baranovka in Posyet, Primorsky Krai, Russia. Studied law at Sverdlovsk State University, graduating in 1937.

- **Career:** Preliminary judge at the City Prosecutor's Office Kyzylorda city, Kazakhstan. Prior to liberation of Korea, worked in the Soviet Army Intelligence. Worked in provincial preliminary court until 1940. Vice Provincial Prosecutor until 1942. 1942-44: Prosecutor in charge of Taldykorgan, Kazakhstan. 1944-45: Prosecutor responsible of Kyzylorda. Sent to North Korea on orders of Soviet Central Committee in 1945. March 1948: member of the Central Committee of the "KWP." Prior to 1951: Director of the Political Security Department of the Ministry of Internal Affairs. 1951: Minister of Public Security (relieved in October 1952). October 1952: Minister of Internal Affairs (until 1958). April 1956: KWP CC Member. November 1960: President of the Supreme Court. November 1966: Director of the Intelligence Department of the Party Liaison Bureau. November 1970: KWP CC Member. December 1972: Member of the Bills Committee of the Supreme People's Assembly and President of the Central Court.

Source: "Biographic Sketches of DPRK Leaders," JPRS 70105, 07 November 1977; Pang Irina, "Mr. Pang Hak-se: Biography of North Korea's Minister of Internal Affairs." Pang Irina was Pang Hak-se's older sister; Andrei Lankov, "Pang Hak-se: founder of NK security police," Korea Times, 22 February 2012.



PAEK HAK-NIM (1918–2006)

- **Education:** Central Party Political School, Academy of Marxism-Leninism, Soviet Military Academy.
- **Career:** Served in Kim Il-sung's Anti-Japanese Commando Unit. Served as a company commander in Kim Il-sung's personal guard. Director of the bodyguard office of the Cabinet. 1962: Director, Political Security Bureau, Ministry of National Defense. November 1967: Deputy of the 4th Supreme People's Assembly. March 1970: Deputy Director of Public Security Department. November 1970: Member of the KWP CC. August 1978: Vice Minister of People's Armed Forces. October 1980: KWP CC Political Bureau member. October 1980: KWP Central Military Committee member. October 1985: Dismissed as KWP CC Political Bureau member; appointed Director of Public Security Department. May 1990: Vice Chairman of the SPA Legislation Committee. April 1992 KPA Vice Marshal. 1996: Minister of Public Security. September 1998: Member of the National Defense Commission, chairman of the SPA Legislation Committee, and Minister of Public Security. April 2000: Minister of People's Security (ministry name changed from the Ministry of Public Security). July 2003: Dismissed as Minister of People's Security.

Source: Ministry of Unification's Key Figures of North Korea 2009; and Japan's Radiopress North Korea Directory 2007.

SOK SAN (1902–?)

- **Birthdate:** 1902 in North Hamgyong Province.
- **Career:** 1930: Jointed anti-Japanese movement. 1948: Director of the Internal Affairs Department of Hwanghae Province. 1951: Director, Political Security Bureau of the Ministry of National Defense. 1956: KWP CC Alternate Member. 1959: Vice Minister of National Defense. 1960: Minister of Interior. 1961: KWP CC Member. 1962: Minister of Public Security. 1966: KWP Party Secretary, Candidate Member of Politburo. 1967: Deputy of 4th SPA. 1968: Awarded Order of the National Flag. 1969: Vice Premier. Purged in 1969 as part of the Kapsan affair.

Source: North Korea Biographic Dictionary, FBIS, No. 304, 24 August 1983 "Biographic Sketches of DPRK Leaders," op. cit.

**WON UNG-HUI** (1936–2004)

- **Career:** October 1983: Major General, Korean People's Army. 1988: Member of the Air Command Political Committee. 1988: KWP CC Alternate Member. April 1990: Deputy of 9th Supreme People's Assembly. December 1991: Member, KWP Central Committee. 1992: Director, MPAF Security Bureau. 1992: Promoted to Lieutenant General. July 1994: General, KPA. 1995: Commander, MPAF's Military Security Command. 1998: Deputy of 10th SPA. Died in May 2004.

Source: Ministry of Unification's Key Figures of North Korea 2009; and Japan's Radiopress North Korea Directory 2007.



RI CHIN-SU (1921–1987)

- **Birthdate:** Unknown.
- **Career:** September 1957: Deputy Procurator General of the Supreme Procurator's Office. 1962: Vice Chairman of the DPRK Lawyers Association. July 1965: Vice Minister of Public Security [An-jeon-seong]. 1970: Lieutenant General. December 1972: Vice Minister of Public Security [An-jeon-bu]; Deputy of 5th SPA. 1973: Minister of Public Security. 1976: Procurator General of the Central Procurator's Office. 1980: KWP CC Member. 1982: Deputy of 7th and 8th SPA. 1982: Director of the SSD. Died in August 1987.

Source: "Biographic Sketches of DPRK Leaders," op. cit.

RI NAM-SON

- **Birthdate:** Unknown
- **Career:** Security functionary. Mid-1980s-1992: Commander MPAF Security Bureau. 1986: KWP CC Alternate Member.

Source: Yi Chong-hun: "We Uncover the Veils of the Security Command of the North Korean Army," Sisa Journal, 06 November 1997; author discussion with South Korean sources.



HAN YONG-OK (?–1988)

• **Career:** 1962: Deputy to 3rd SPA. 1964: Chief Secretary, Changsong County Party Committee. 1970: Promoted to Major General. 1970: KPA Representative to Military Armistice Commission, Panmunjom. Involved in negotiations for return of North Korean MIG 15 pilot who supposedly defected to South Korea. 1972: Deputy to 5th SPA. 1973: Director of Propaganda Department of the GPB. 1973: Deputy Director of the GPB for Propaganda. 1979: Promoted to Lieutenant General. Late 1970s-Mid 1980s: Commander of the MPAF Security Bureau. 1980: Member of the KWP Central Committee. 1982: Deputy to the 7th SPA.

Source: Dae-Sook Suh, Korean Communism: 1945-1980 (Honolulu, HI: The University of Hawaii, 1981); "North Korea Makes Effort to Secure Pilot's Release," AP, 06 December 1980; author discussion with South Korean sources.

TAE PYONG-RYOL (1919–1997)

• **Career:** 1940s: Courier for Kim Il-sung. 1956: KWP Central Committee Deputy Department Director. 1961: KWP CC Alternate Member. 1962: Deputy to the 3rd SPA. 1965: Director of a KWP CC department. 1967: Director of Ministry of Public Security Border Guards Bureau. 1970: Awarded Title Hero of the Republic and Order of National Flag First Degree. 1970: Director of the KWP Military Department. 1970: KWP CC Member. 1972: Deputy to 5th SPA. 1976: Promoted to Lieutenant General. Mid 1970s: Commander of the MPAF Security Bureau. 1980: KWP CC Member. 1980: KWP Central Military Committee Member. 1982: Awarded Order of Kim Il-sung. 1982: Director of a KWP CC department. 1985-97: Director of Victorious Fatherland Liberation War Museum. 1986: Promoted to Colonel General. 1986: Deputy of 8th SPA. 1990: Deputy of the 9th SPA. 1992: Promoted to General and Awarded Title of Hero of Republic. 1994: Member of Kim Il-sung's Funeral Committee.

Source: North Korea Biographic Dictionary, FBIS, No. 304, 24 August 1983; Dae-Sook Suh, Korean Communism: 1945-1980 (Honolulu, HI: The University of Hawaii, 1981); Japan's Radiopress North Korea Directories; "Death of Tae Pyong-ryol," KCNA, 05 February 1997.

PAK IL-U (1919–1997)

- **Birthdate:** Unknown
- **Career:** Before creation of DPRK, Pak Il-u was one of the leaders of the pro-China Yanan Faction. Was a deputy commander of the KVA. After creation of DPRK, Pak was de facto personal representative of Mao Zedong within the North Korean leadership. 1948-53: Minister of Internal Affairs. During the Korean War, Pak was political commissar for the KPA forces, removed after the fall of Pyongyang. Late 1950s: Purged from leadership in mid-1950s.

Source: Andrei Lankov, "The Repressive System And The Political Control In North Korea," op. cit.

**CHOE YONG-GON** (1902–1976)

- **Birthdate:** 1920 in the province Pyongan Province.
- **Career:** Choe visited two military academies in his youth and was active in the armed resistance against Japanese colonial rule over Korea. In 1927 he was involved in communist riots in the southern city of Guangzhou. After the occupation of Manchuria by the Japanese in 1931, he led an anti-Japanese guerrilla unit. In 1936, he became an officer of the Korean People's Revolutionary Army. Following the establishment of the Provisional People's Committee of North Korea in 1946, Choe became the director of the Protection and Security Bureau. In February 1948, he was appointed commander of the North Korean troops and remained in this position throughout the Korean War. After the war, he became Minister of Defense of North Korea. In 1957, he was appointed Chairman of the Presidium of the Supreme People's Assembly. He remained in this position until 1972. As head of state, Kim Il-sung followed him in the newly created office of the president. Choe died on 19 September 1976.

Source: Compilation of North Korean and South Korean sources.

APPENDIX II: AN EXAMPLE OF A NORTH KOREA MINISTRY OF PEOPLE'S SECURITY DECREE

2) Accept only our money when payments are received by the state agencies for all sorts of service charges, transportation fees, and all other payments—payments which used to be made with foreign currencies.

3) All trading agencies (including joint venture and joint business units), supply imported goods according to the state plan and never commit the profiteering and racketeering acts of turning imported goods over to agencies, enterprises, public cooperative organizations, and citizens that are not included in the state plan and that thus foster illegal foreign currency circulation.

4) All citizens, strictly observe the order of using foreign currencies by exchanging them with our currency without fail at the currency exchange stations and never commit the acts of black-marketing, peddling, usury, swindling, fraudulence, brokerage, smuggling, bribery, or seizure by use of foreign currencies.

5) All agencies, enterprises, and public cooperative organizations, receive the supply of necessary foreign currencies based according to the state plan.

II. All units, except for the units authorized by the state, abolish all domestic trade indices [*Guk-nae Su-chul Jip-yo*] and completely cease illegal foreign currency non-cash transactions between domestic agencies, enterprises, and public cooperative organizations.

3. Relevant banking agencies, correctly establish the system and order of exchanging foreign currencies with our currency and carry out exchange work in a responsible manner.

4. All agencies, enterprises, public cooperative organizations, and citizens, never commit the acts of meddling in or hampering the work of the overseeing and controlling agencies and functionaries that crack down on and control illegal foreign currency circulations and immediately report to the law-enforcement agencies if the illegal acts of domestically paying with or accepting foreign currencies are noticed.

5. If agencies, enterprises, and public cooperative organizations violate this decree, their business activities and operation shall be suspended or abolished and the money and goods that have been traded shall be confiscated. For those who buy or sell goods with foreign currencies, those who black-market foreign currencies, those who illegally circulate or seize foreign currencies, including those who commit acts of usury, brokerage, or bribery, and those who arrange, overlook, or facilitate such acts, the money and goods that have been traded shall be confiscated, and they shall be strictly punished by law, including capital punishment, based on the degree of graveness.

6. This decree will be applicable from January 1, 2010 to all state agencies, enterprises, public cooperative organizations (including armed forces and special agencies), citizens, and foreigners.

[signed] the DPRK Ministry of People's Security

[dated] 28 December, Juche 98 (2009)

APPENDIX III: AN EXAMPLE OF A NORTH KOREAN ARREST WARRANT

This is reportedly an arrest warrant issued by the prosecutor's office in Hoeryong City, North Hamgyong Province. It was published in the Japanese magazine *Yomiuri Weekly*. The warrant reads:

In accordance with Statute 107 of the Code of Criminal Procedure, the accused shall be placed in custody for violation of the crimes proscribed in Additional Clause 39 of the Criminal Code.²⁷⁵

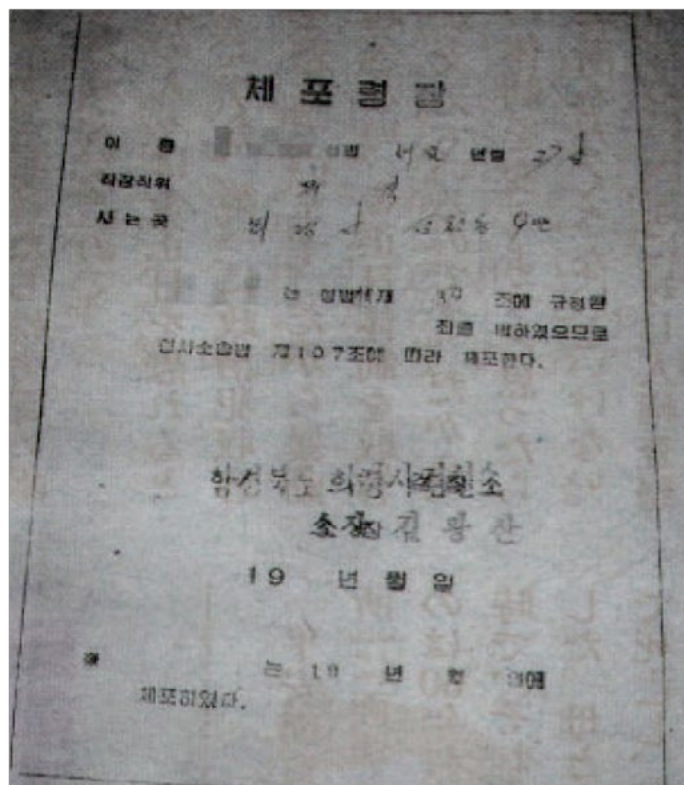

275 "North Korean Defectors Reveal Brutal Life in DPRK Prison Camps," *Yomiuri Weekly*, 04 May 2008.



The Committee for Human Rights in North Korea

1001 Connecticut Avenue, NW

Suite 435

Washington, DC 20036

(202) 499-7973

www.hrnk.org